

Mity-Mite Module
Embedded 386SX CPU Series
User's Manual

(Version 1.0)

Copyright Notice

This document is copyrighted, 2001 by ICOP Technology Inc. All rights are reserved. The information in the manual is subject to change without notice in order to improving products.

No part of this manual may be reproduced, copied, translated or transmitted in any form or by any means without the prior written permission of the manufacturer.

ICOP Technology Inc. assumes no responsibility for any inaccuracies that may be contained in this document. ICOP Technology Inc. makes no commitment to update or to keep current the information contained in this manual.

©Copyright 2001 by ICOP Technology Inc.
All rights reserved. Ver.1.0 2001,
Printed in Taiwan

Trademarks Acknowledgments

All brand names and trademarks are the properties and registered brands of their respective owners.

Table of Contents

Chapter 0 Startup

0.1	Packing List	1
0.2	Specifications	2
0.3	Component Location	3

Chapter 1 Introduction

1.1	Features	4
1.2	Specifications	5

Chapter 2 Installation

2.1	Jumper Settings	7
2.2	Connectors	8
2.3	Software Installation	9
2.3.1	Start Up Mity-Mite Module	9
2.3.2	How to copy Software from HDD into Onboard Electronics Floppy Drive A:	10
2.3.3	How to Use 44 pin MicroDisk Module	11
2.3.4	How to Install the Software into 44 pin MicroDisk Module	12
2.4	Watchdog Timer	13
2.5	General Purpose I/O	20

Chapter 3 Network Interface

3.1	Introduction	22
3.2	Software Support	22

Appendix Pin assignment

IDE Interface Connector	23
Serial Port Interface	24
Keyboard and PS/2 Mouse Connector	25
16-bit General Purpose I/O	25
ISA Bus Connector	26

Warranty 27

Chapter 0

Startup

0.1 Packing List

Product Name	Function	Package
Mity-Mite Module	Embedded 386SX Board with LAN	<ul style="list-style-type: none">● Mity-Mite Module 386SX CPU Board with LAN● Utility and Drivers Diskette x 1● RS232 cable x 1● 44 pin to 40 pin IDE cable x 1● AT KB / PS2 Mouse cable x 1

0.2 Specifications

Feature	OP-60156
Chipset	DM&P(ALi) M6117D
BIOS	AMI BIOS
Watchdog Timer	From 30.5µs to 512 seconds
Bus Interface	ISA bus signal interface
Memory	2MB onboard (4MB optional)
I/O Chip	ALi 5113
Keyboard Connector	1
IDE port	1
Serial Port	RS232 X 1
Digital I/O	16 Bit
Parallel Port	1
Network Chipset	Realtek 8019AS
Network Interface	RJ-45
Power Requirement	+5V @0.4A
Board Weight	70g
Board Size	80 X 50mm
Operating Temperature	-20 ~ +60°C

0.3 Component Location

Mite-Mite Module

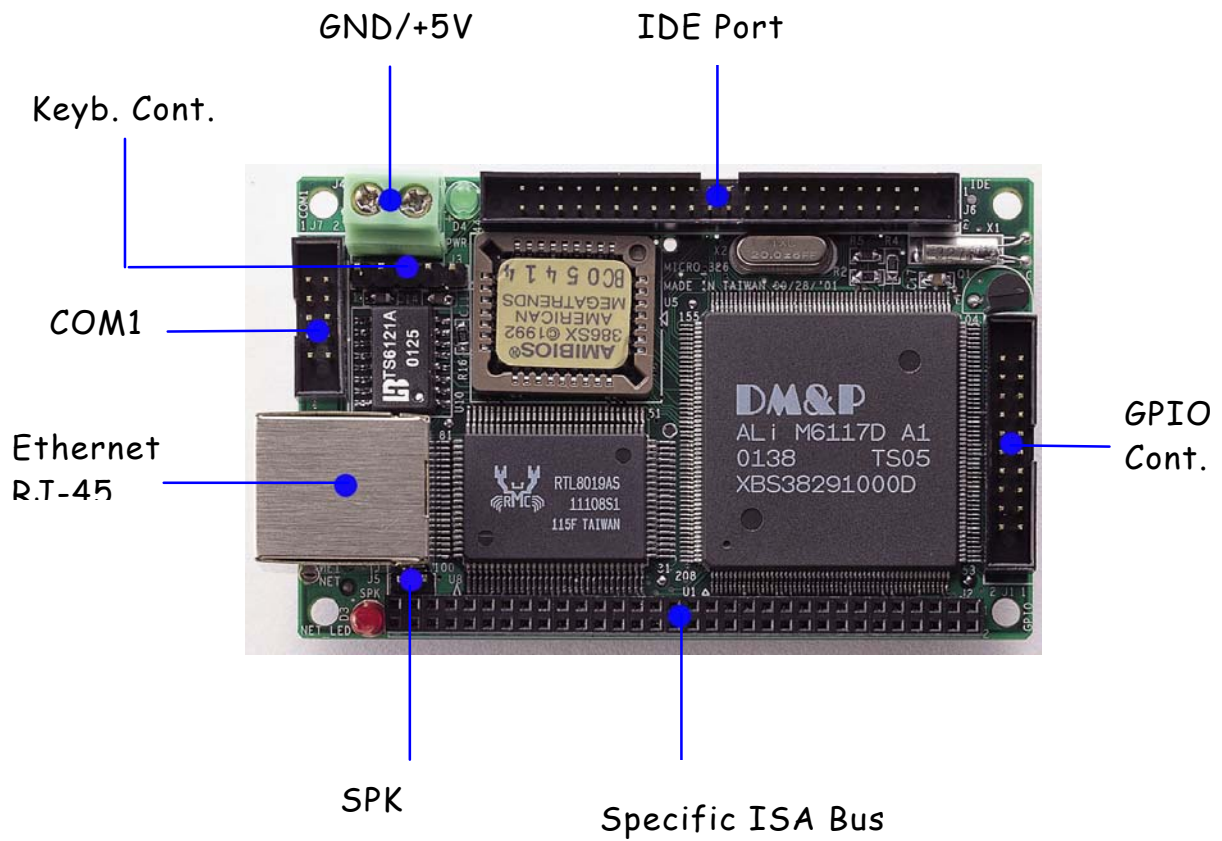

Chapter 1

Introduction

1.1 Features

- Mity-Mite (80x50 mm) 386SX Embedded CPU Modules
- 8-bit ISA-bus signal interface
- DM&P (ALi) M6117D Embedded CPU, compatible with 386SX CPU
- 2MB / 4MB EDO RAM onboard
- One Enhanced IDE Port
- RS-232 interface
- Watchdog timer
- 16-bit GPIO connector onboard
- Onboard AT-keyboard header
- Onboard Ethernet, compatible with NE2000
- Single voltage +5 V power connector
- Operating temperature from -20 • +60•
- Flexible OEM/ODM design

1.2 Specifications

- **Embedded CPU :** DM&P(ALi) M6117D is an implementation of an INTEL compatible 386SX CPU, Realtime clock, a watchdog timer and ALi's M1217B chipset

- **BIOS:** Y2K compliant AMI system BIOS

- **DRAM Memory:** 2MB / 4MB EDO DRAM onboard

- **Bus Interface:** ISA bus signal interface

- **Data Bus:** 16-bit

- **Bus Speeds:** PC/104 - 8 MHz

(above values are defaults, bus speeds are programmable up to 16 MHz)

- **DMA Channels:** 7

- **Interrupt Levels:** 15

- **Watchdog Timer:** generates either a RESET, NMI or an IRQ when your application loses control over the system. Optionally the watchdog can trigger a user specified interrupt. The watchdog is configurable from 30.5 μ s to 512 seconds (in 30.5 μ s segments)

- **Real-time Clock:** included in M6117D with onboard lithium battery backup for 10 years of data retention. CMOS data backup of BIOS setup and BIOS default.

High Speed Multi I/O

- **Chipse :** ALi 5113 or SMS CFDC37C669

- **Serial ports:** Supports high speed RS-232 port, with 16C550 UART and 16 byte FIFO. BIOS enabled/ disabled

Environmental and Power

- **Power Requirements:**

single voltage +5 V

- **Board Dimensions:** 80 (L) x 50 (W) mm.

- **Board Weight:** 70 g

- **Extended Operating Temperature:** -20~+60 °C

Network Interface

- **Chipset:** Realtek 8019AS single chip
- **Type:** 10BASE-T
- **Connectors:** onboard RJ-45 connectors
- **Monitoring LEDs:** network ready indicator, network activity indicator
- **Compatibility:** NE2000

Chapter 2

Installation

2.1 Jumper Settings

Mity-Mite Module

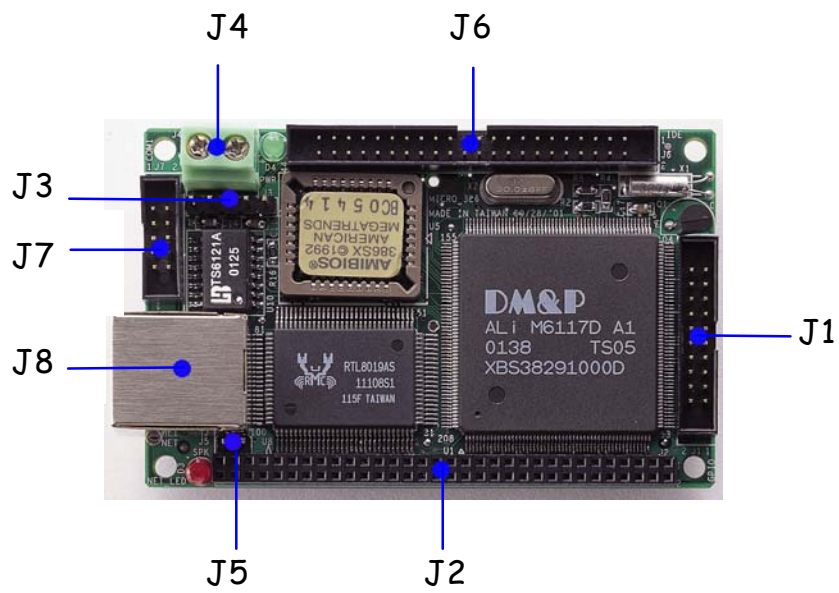

2.2 Connectors

J1	20-pin header for 16-bit GPIO
J2	64-pin ISA bus
J3	5-pin keyboard connector
J4	+5V Power connector
J5	For external speaker
J6	44 pin header for IDE port
J7	10 pin header for RS-232
J8	LAN RJ45 connector

2.3 Software Installation

By special technology, Mity-Mite Module integrates 64KByte BIOS and approximately 400KByte electronics Floppy Drive A: into an onboard 512K flash chip. Also, the DOS (Dr. DOS or X-DOS) has already pre-installed into the electronic Floppy Drive A:.

If your application software is less than 300KByte, then you can install it into this electronics Floppy Drive A without any extra storage.

2.3.1 Start Up Mity-Mite Module

It is very easy to get Mity-Mite Module start to work. Please refer below picture. First of all, you can just stack the Mity-Mite Module with Mity-Mite VGA/LCD Development Kit together. Then, connect all the necessary accessories (such as monitor and keyboard, etc.) and power on it (+5V). Thus, you will get into the DOS prompt mode directly within few seconds.

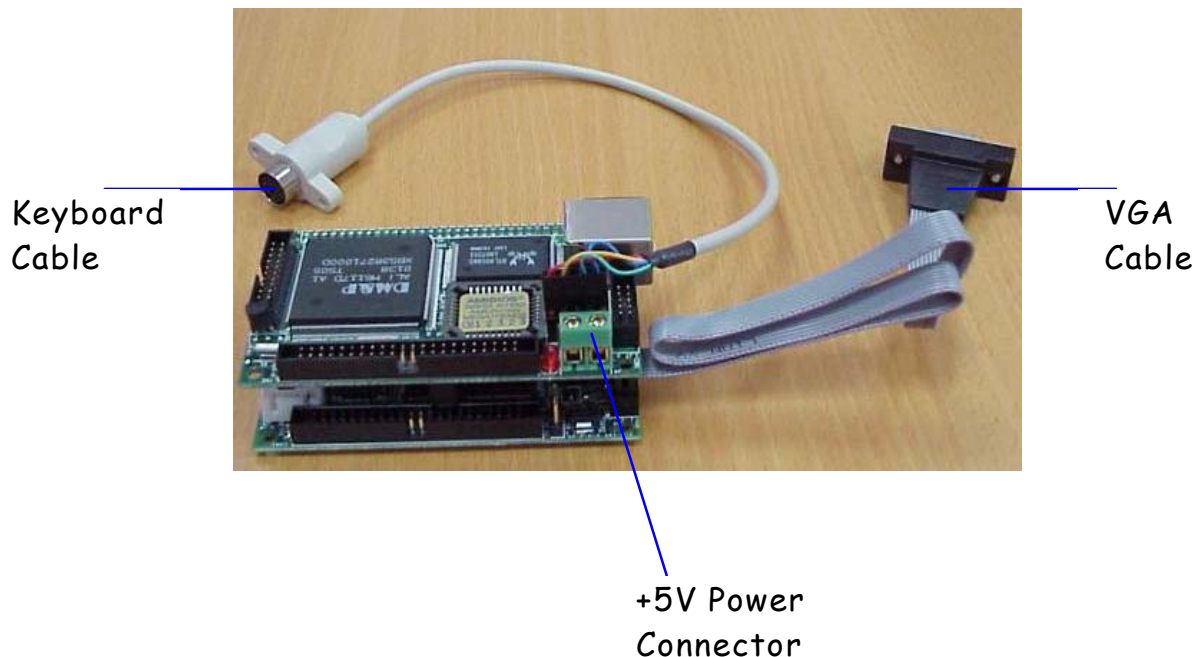

2.3.2 How to copy Software from HDD into Onboard Electronics Floppy Drive A:

There is still around 300KByte free in onboard electronics Floppy A:.. You can simply connect hard-disk on IDE interface of Mity-Mite Module and become Drive C:.. Please refer below picture.

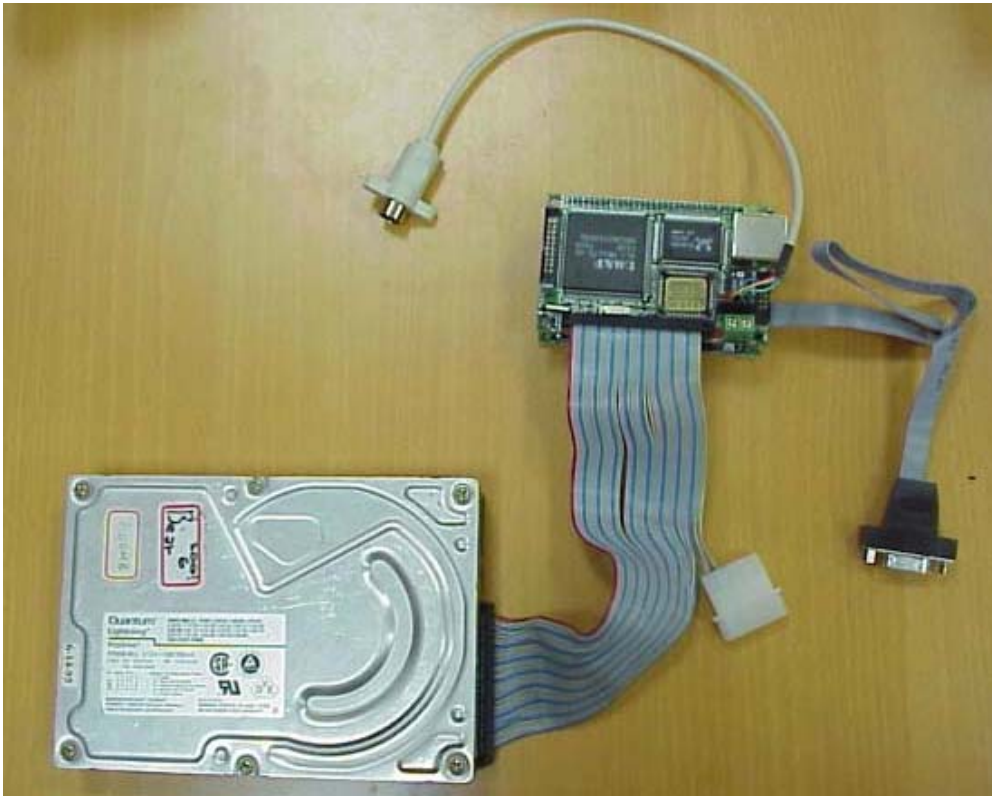

We provide a 44-to-40 pin IDE cable with Mity-Mite Module. Please use it to connect the hard-disk to Mity-Mite Module. Then you can copy your software from hard-disk Drive C: into onboard electronics Floppy disk A:..

2.3.3 How to Use 44 pin MicroDisk Module

If your application software is more than 300KByte then you may need to use MicroDisk Module on Mity-Mite Module. MicroDisk Module can support large Flash storage from 4 Mbyte and up to 256Mbyte on IDE interface, normally.

Please note there are two types of MicroDisk Module, vertical and horizontal, and Mity-Mite Module can support both of two types.



Vertical type



Horizontal type

2.3.4 How to Install the Software into 44 pin MicroDisk Module

Normally, the onboard IDE interface is using 40-pin (2.54 pitch) connector. So, you need some tool to transfer data from 40-pin HDD into 44-pin (2.0 pitch) MicroDisk Module. Here, we provide a board, named ICOP-0092, which can support you for this kind of transfer.



First, please connect 44-pin MicroDisk Module on ICOP-0092. Then, use IDE flat cable to connect both hard-disk and CPU board (any board is okay, as long as it is with 40-pin IDE interface). Thus, you can copy the software from hard-disk (Drive C:) to MicroDisk Module (Drive D:)

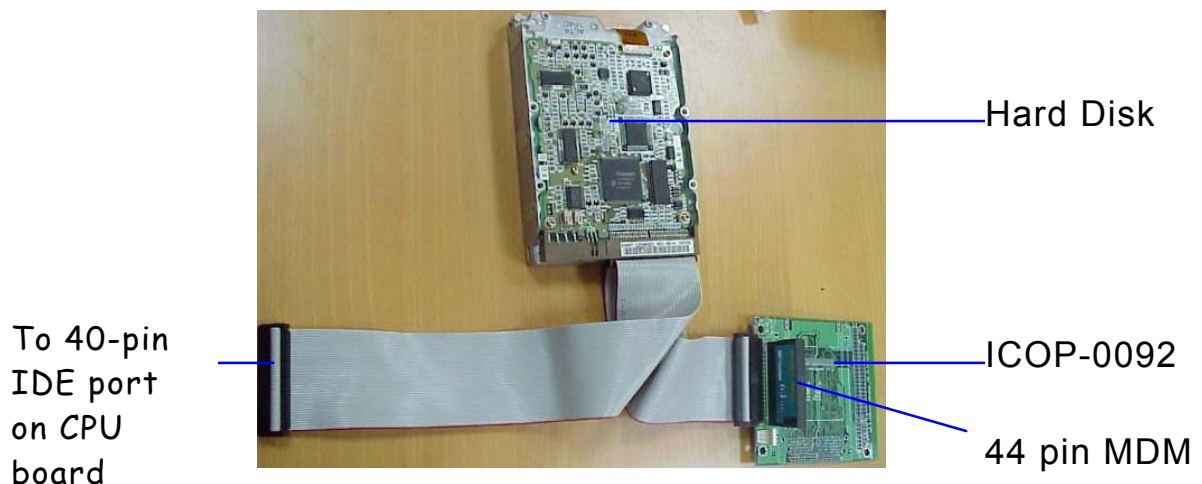

2.4 Watchdog Timer

The watchdog timer uses a 32.768 KHz frequency source with a 24-bit counter. Its time range stretches from 30.5 ms to 512 sec. with a resolution of 30.5 ms. When the watchdog times out a System RESET, NMI or IRQ can be invoked. Watchdog timer control and the 24-bit counter itself occupy 6 consecutive 8-bit address locations.

When functioning properly the system resets the watchdog timer periodically to prohibit that it times out. If the watchdog timer times out, it will RESET the system, or generate and NMI or IRQ, depending on its configuration.

Watchdog or System Timer

Another great application is to generate a periodic IRQ signal. Under DOS environment, the 8254, system timer 0, will generate IRQ0 every 54.9 ms. The watchdog is like system timer 0. It can be programmed to periodically generate a configurable IRQ. It may be clear that the selected IRQ, will be no longer available to the system.

Configuring the Watchdog Timer in the BIOS

The M6117D watchdog configuration register can be controlled by software or can be setup in the BIOS. To do so go to BIOS Setup's "Advanced Chipset Setup"

Watchdog Function = Enable/Disable

Watchdog Signal = RESET, NMI or IRQ

3/4/5/6/7/9/10/11/12/14/15

Watchdog Timer = 1/2/4/8/16/32/64/128/256/512 Seconds

The BIOS setup only offers a limited amount of time-out values. More a higher resolution of timeout values refer to the next paragraph "Configuring the Watchdog Timer by Software" Note that in case of using the BIOS setup, the watchdog starts counting the moment it passes the BIOS setup. This means that if you set the time-out period to 1 second, the system will keep rebooting before being able to load operating system or software !

After you have finished configuring you watchdog timer read "Timeout Status & Reset - INDEX 3CH" on page 12 and look at the example on page 15 to find out how to periodically resetting the timeout status to prevent the watchdog timer from invoking a RESET, NMI or IRQ.

Configuring the Watchdog Timer by Software

Chipset configuration registers

The M6117D configuration register INDEX 37H, 38H, 39H, 3AH, 3BH, 3Ch are used to control the watchdog functions and/or display its current status.

Enable/Disable watchdog - INDEX 37H

Bit	Value	Action
7	reserved	Do not modify the value of these bits!
6	0	Disable watchdog timer
	1	Enable watchdog timer
5-0	Other function	Do not modify the value of these bits!

Watchdog time out action - INDEX 38H

Bit	Value	Action
7-4	0000	No output signal
	0001	IRQ3
	0010	IRQ4
	0011	IRQ5
	0100	IRQ6
	0101	IRQ7
	0110	IRQ9
	0111	IRQ10
	1000	IRQ11
	1001	IRQ12
	1010	IRQ14
	1011	IRQ15
	1100	NMI
	1101	System RESET
	1110	No output signal
	1111	No output signal
3-0	Other function	Do not modify the value of these bits!

Watchdog timer - INDEX 39H, 3AH, 3BH

Index	3Bh	3Ah	39h
Bits	D7.....D0	D7.....D0	D7.....D0
counter	[VSB.....LSB]

For example

Index	3Bh	3Ah	39h	Time out
	00h	00h	01h	30.5µs
	00h	00h	02h	61µs
	00h	01h	00h	7.8 ms
	00h	02h	00h	15.6 ms
	01h	00h	00h	2 s
	02h	00h	00h	4 s
	FFh	FFh	FFh	512 s

Timeout Status & Reset - INDEX 3CH

Bit	Value	Action
7	0	Timeout has not occurred
	1	Timeout has occurred
6	1	Reset timer
	0	Has no meaning
5-0		Other function, do not modify these bits

Programming the watchdog

To perform any operation on the M6117D configuration registers you always

have to unlock first and lock the registers afterwards

Unlock configuration register

```
mov al, 013h
```

```
out 22h, al
```

Lock configuration register

```
mov al, 013h
```

```
out 22h, al
```

<code>nop</code>	<code>nop</code>
<code>nop</code>	<code>nop</code>
<code>mov al, 0c5h</code>	<code>mov al, 000h</code>
<code>out 23h, al</code>	<code>out 23h, al</code>
<code>nop</code>	<code>nop</code>
<code>nop</code>	<code>nop</code>

Read the value of a configuration register

For example, read INDEX 3Ch :

Unlock configuration register

```

mov al, 03ch
out 22h, al
nop
nop
in al, 23h
nop
nop
push ax

```

Lock configuration register

```

pop ax ;AL - result

```

Write data to configuration register

For example, write 0FFh to INDEX 3Bh :

Unlock configuration register

```

mov al, 03bh
out 22h, al
nop
nop
mov al, 0ffh
out 23h, al

```

```
nop
```

```
nop
```

Lock configuration register

Watchdog Program Example

We use the following sequence to initialize the watchdog timer:

- (1) Unlock configuration register.
- (2) Disable watchdog timer by setting INDEX 37H Bit 6 to '0'.
- (3) Set the expected counter value to INDEX 3BH, 3AH, 39H.
- (4) Select timeout action from INDEX 38H Bit 7-4.
- (5) Enable watchdog timer by setting INDEX 37H Bit 6 to '1'.
- (6) Lock configuration register.

Example: Set timeout to 128 sec to generate a system RESET.

```
; Please use MASM to compiler the following program
```

```
; Execute under DOS environment
```

```
dosseg
```

```
. model small
```

```
. stack 100h
```

```
.code
```

```
main proc
```

```
    mov ax, 0c513h ; Unlock config. register
```

```
    call writechip
```

```
    mov ax, 03737h ; Disable watchdog timer
```

```
    call readchip
```

```
    and al, 10111111b
```

```
    xchg ah, al
```

```
    call writechip
```

```
    mov ax, 0403bh ; Set the expected counter
```

```
            ; value
```

```
    call writechip ; to [400000h]
```

```

mov ax, 0003ah ; 30.5*sec*400000h= 128 sec
call writechip
mov ax, 00039h
call writechip
mov ax, 03838h ; Select "system reset" as
                ; timeout action
call readchip
and al, 00001111b
or al, 11010000b
xchg ah, al
call writechip
mov ax, 03737h ; Enable watchdog timer
call readchip
or al, 01000000b
xchg ah, al
call writechip
mov ax, 00013h ; Lock config. register
call writechip
mov ax, 04c00h
int 21h
main endp

readchip proc
out 22h, al
nop
nop
in al, 23h
nop
nop

```

```

        ret
readchip endp
writechip proc
        out 22h, al
        nop
        nop
        xchg ah, al
        out 23h, al
        nop
        nop
        xchg ah, al
        ret
writechip endp
end main

```

Reset watchdog timer

Resets the watchdog timer periodically to prevent timeout.

```

        mov ax, 0c513h ; Unlock configuration
                        ; register
        call writechip
        mov ax, 03C3Ch ; Reset watchdog timer
                        ; counter
        call readchip
        or al, 01000000b ; The counter is reset at
        xchg ah, al ; out 23h, al
        call writechip
        mov ax, 00013h ; Lock configuration
                        ; register
        call writechip

```

(the above code uses readchip and writechip procedures)

2.5 General Purpose I/O

M6117D supports 16 independent GPOs and GPIs. This group of GPOs does not need external 74LS373 to latch as generate purpose output. Also this group of GPIs do not share signals with the ISA data bus, so no external 74LS245 is required either.

At boot time the state of the GPIO ports can be set in the BIOS.

Go to BIOS Setup's "**Advanced Chipset Setup**"

GPIO Sample Program

; Please use TASM to compiler the following program.

; Execute under DOS environment.

;

.286

.model small

.code

mov al,13h ; Unlock 6117D configuration register.

out 22h,al ;

mov al,0c5h ;

out 23h,al ;

mov al,4eh ; Enable GPIO[7-0] is output pin.

out 22h,al ;

mov al,0ffh ; If AL fill "FF", then
; GPIO[7-0] set as output pin.

out 23,al ; User can be set logic "1"
; of OUT direction.

mov al,4fh ; Enable GPIO[15-8] is input pin

out 22h,al ;

mov al,00 ; If AL fill "00", then
; GPIO[15-8] set as input pin.

```

out 23h,al      ; User can be set logic "0"
                ; of IN direction.

mov al,47h     ; Output data port.
out 22h,al     ;
mov al,55h     ; Example data out value is 55h,
                ; to output pin

out 23h,al     ; GPIO[7-0]. So user can
                ; repeat this loop.

mov al,46h     ; If GPIO[7-0] is set input direction, then data
out 22h,al     ; input port is 46.
in al,23h     ; Example data input value
                ; from data input GPIO[7-0]

mov al,4ch     ; Input data port
out 22h,al     ;
in al,23h     ; Read data from GPIO[15-8]
                ; into AL register.

mov al,4dh     ; If GPIO[15-8] is set output
                ; direction, then data

out 22h,al     ; output port is 4dh.
mov al,55h     ; output data value is 55h.
out 23h,al     ; Example data output value
                ; to data input GPIO[15-8]

..... continue program
end

```

Chapter 3

Network Interface

3.1 Introduction

The Realtek RTL-8019AS 10Mbps Ethernet controller board supports both 10BASE-T and Coax 10Base-2 'BNC' connectors, and allows direct connection to your 10Mbps Ethernet based Local Area Network for full interaction with local servers, wide area networks such as the Internet.

I/O and IRQ settings can be done by software with the supplied utility software, or it can be set for Plug and Play compatibility. The controller supports : Full-Duplex Ethernet function to double channel bandwidth, auto media detection.

3.2 Software Support

On-board EEPROM (93C46) programming

Setup/Diagnostic program for DOS

Help utility for easy installation

RPL boot ROM for Novell Netware, Microsoft NT

NDIS2 (DOS,OS/2,Lantastic,WFW3.1jKjK)

NDIS3,NDIS4,NDIS5 for WIN95,98,NT3.51,4.0,5.0,WFW3.11

Netware 16-bit ODI driver for DOS,OS/2 and 32-bit ODI driver for Netware 3.x,4.x,5.0 Server

Packet driver for UNIX Client

SCO Unix driver

Linux driver

All operating systems that support standard NE2000

Appendix

A. Pin assignment

IDE Interface Connector

Pin	Description	Pin	Description
1	Reset	2	GND
3	Data 7	4	Data 8
5	Data 6	6	Data 9
7	Data 5	8	Data 10
9	Data 4	10	Data 11
11	Data 3	12	Data 12
13	Data 2	14	Data 13
15	Data 1	16	Data 14
17	Data 0	18	Data 16
19	GND	20	N/C
21	N/C	22	GND
23	IOW #	24	GND
25	IOR #	26	GND
27	N/C	28	BALE-Default
29	N/C	30	GND-Default
31	Interrupt	32	IOCS16-Default
33	SA1	34	N/C
35	SA0	36	SA2
37	HDC CS0	38	HDC CSI #
39	HDD Active	40	GND
41	Vcc	42	Vcc
43	GND	44	N/C

Serial Port Interface

10- Pin	D-Type	Description
1	1	Data Carrier Detect (DCD)/5V/12V
2	2	Receive Data (RXD)
3	3	Transmit Data (TXD)
4	4	Data Terminal Ready (DTR)
5	5	Ground (GND)
6	6	Data Set Ready (DSR)
7	7	Request to Send (RTS)
8	8	Clear to Send (CTS)
9	9	Ring Indicator (RI)/5V/12V
10	X	NC

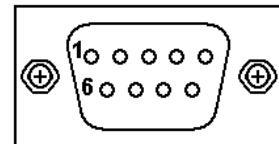
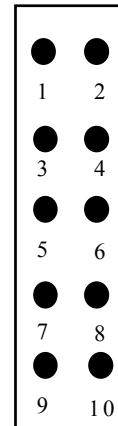

Keyboard and PS/2 Mouse Connector

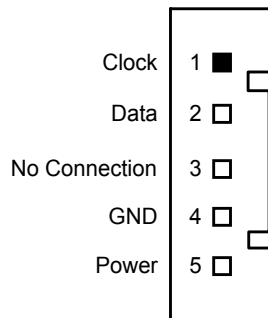

Note for Keyboard:

Pin1: KBCLK
Pin2: KBDATA

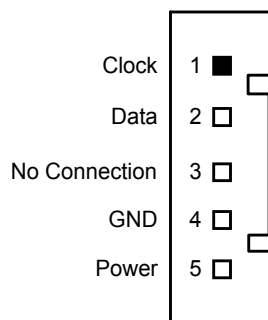

Note for Mouse:

Pin1: MCLK
Pin2: MDATA

16-bit General Purpose I/O

Pin	Description	Pin	Description
1	GND	2	Vcc
3	GP0	4	GP8
5	GP1	6	GP9
7	GP2	8	GP10
9	GP3	10	GP11
11	GP4	12	GP12
13	GP5	14	GP13
15	GP6	16	GP14
17	GP7	18	GP15
19	Vcc	20	GND

ISA Bus Connector

J2

PIN No.	PIN Name	PIN No.	PIN Name
1	GND	2	SBHE
3	RSTDRV	4	SD7
5	Vcc	6	SD6
7	SD8	8	SD5
9	SD9	10	SD4
11	SD10	12	SD3
13	SD11	14	SD2
15	SD12	16	SD1
17	SD13	18	SD0
19	GND	20	IOCHRDY
21	SMEMW	22	AEN
23	SMEMR	24	SA19
25	IOW	26	SA18
27	IOR	28	SA17
29	SD14	30	SA16
31	SD15	32	SA15
33	MEMCS16	34	SA14
35	IOCS16	36	SA13
37	REFRESH	38	SA12
39	SYSCLK	40	SA11
41	IRQ7	42	SA10
43	IRQ6	44	SA9
45	IRQ5	46	SA8
47	IRQ4	48	SA7
49	IRQ3	50	SA6
51	IRQ10	52	SA5
53	IRQ11	54	SA4
55	ALE	56	SA3
57	Vcc	58	SA2
59	OSC	60	SA1
61	GND	62	SA0
63	IRQ12	64	IRQ14

Warranty

This product is warranted to be in good working order for a period of one year from the date of purchase. Should this product fail to be in good working order at any time during this period, we will, at our option, replace or repair it at no additional charge except as set forth in the following terms. This warranty does not apply to products damaged by misuse, modifications, accident or disaster. Vendor assumes no liability for any damages, lost profits, lost savings or any other incidental or consequential damage resulting from the use, misuse of, or inability to use this product. Vendor will not be liable for any claim made by any other related party. Return authorization must be obtained from the vendor before returned merchandise will be accepted. Authorization can be obtained by calling or faxing the vendor and requesting a Return Merchandise Authorization (RMA) number. Returned goods should always be accompanied by a clear problem description.