

WinCON 8000

Compact Embedded Controller

Hardware User's Manual

REV 4.1.0.01

2003/7/1



Warranty

All products manufactured by ICP DAS are warranted against defective materials for a period of one year from the date of delivery to the original purchaser.

Warning

ICP DAS assumes no liability for damages consequent to the use of this product. ICP DAS reserves the right to change this manual at any time without notice. The information furnished by ICP DAS is believed to be accurate and reliable. However, no responsibility is assumed by ICP DAS for its use, nor for any infringements of patents or other rights of third parties resulting from its use.

Copyright

Copyright 2003 by ICP DAS. All rights are reserved.

Trademark

The names used for identification only maybe registered trademarks of their respective companies.

Table of Contents

1. INTRODUCTION.....	4
1.1 PACKAGE LIST & RELEASE NOTE.....	4
1.2 WINCON8000 SERIES.....	5
1.3 CONTENTS OF CD AND CF MEMORY CARD.....	7
2. HARDWARE INFORMATION.....	8
2.1 FRONT VIEW OF WINCON8000.....	8
2.2 SPECIFICATIONS.....	9
3. APPLICATIONS.....	10
4. QUICK START	11
5. MECHANICAL INFORMATION.....	12
5.1 DIMENSIONS.....	12
5.2 DIMENSIONS RAIL MOUNTING.....	12
5.3 WALL MOUNTING.....	12

1. Introduction

1.1 Package List & Release Note

Package List

In addition to this manual, the package includes the following items:

- One set of WinCon8000 hardware
- One Compact Flash Memory Card for storing system files
- One hardware user's manual (this manual)
- One release note
- One software utility CD with Software User's Manual included

Note

If any of these items are missing or damaged, contact the local distributors for more information. Save the shipping materials and cartons in case you want to ship in the future.

Release Note

It is recommended to read the **release note & README.TXT** firstly. The release note is included in the shipping products. And the README.TXT is given in the CD\README.TXT. Some important information are provided in the release note & CD\README.TXT

Ordering Information

Call distributor for details.

1.2 WinCon8000 Series

The Wincon-8000 is the flagship compact embedded controller manufactured by ICPDAS. Its leading technology gives you all of the best features of both traditional PLCs and Windows capable PCs. The Wincon-8000 system is powered by Windows CE.NET and brings Windows programming style and skill into the world of PC-based PLC. The application developers can directly develop their own programs in Microsoft's Visual Studio .NET and Embedded Visual tools with Wincon SDK, and then download them into Wincon-8000 for application. Or, they can port their favorite SCADA software onto Wincon-8000 for more ease of application development. For the SCADA application, we also provide a product model embedded with InduSoft Web Studio run-time version to meet your need.

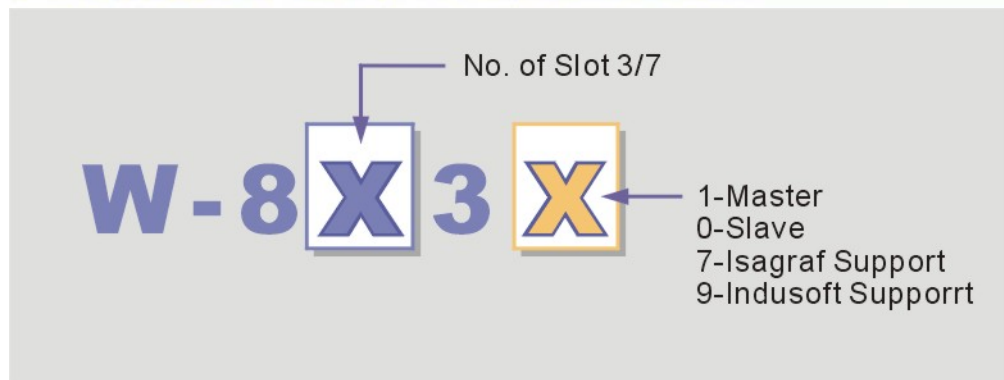

The model type of WinCon-8000 is ruled as W-8X3X, as shown in the above figure. The Second number shows the slot numbers coming with the main controller unit. Currently, we provide two types of 3 and 7 slots. The last number demonstrates the application platform, which include 1, 0, 7 and 9. 1 stands as the Master controller and it means user need to design the application program by themselves. 0 represents the slave controller and it means ICP DAS will provide a firmware into the system to run the default application. However, this function will be released in the future and

depends on the client request. The number 7 indicates the IsaGraf SoftPLC application platform and that means user can develop and run the SoftPLC program within the controller. The number 9 provides the SCADA application platform with InduSoft Web studio Run-time version on the system. And that means client can use the development tool of InduSoft Web studio to develop the application and download it on the controller for application. For more detail products specification, please refer to the following product model table.

Model	Description	CPU Speed	Embedded OS	Slot	Flash	SDRAM	Peripherals
W-8331 W-8731	Embedded Controller	206MHz	Windows CE .NET	3 7	32 Mbyte	64Mbyte	10BaseT Ethernet Portx1 VGA Portx1 CF Slotx1 USBx1 PS/2 Keyboardx1 PS/2 Mousex1 RS-232x1 RS-485x1 FRnetx1(Option)
W-8337 W-8737	ISaGRAF Embedded Controller	206MHz	Windows CE .NET	3 7	32 Mbyte	64Mbyte	
W-8339 W-8739	InduSoft Embedded Controller	206MHz	Windows CE .NET	3 7	32 Mbyte	64Mbyte	

1.3 Contents of CD and CF memory card

CD :

- WinCon8000 SDK
- Wincon Utilities
- Source code of demo programs
- Software User's Manual
- InduSoft User's Manual

References are given in ReadMe.txt in the CD

CF memory card (default is 128 Mbytes):

- WinCon8000 System files
- Wincon Utilities
- Demo programs
- InduSoft system(for W-8739/W-8339 only)
- Directories for FTP server and Http server

References are given in Software User's Manual bundled CD

2. Hardware Information

The WinCon 8000 system competes in performance with Industrial PCs, but lower in price. The system provides VGA and PS/2 keyboard/mouse for local visualization and management. User control programs and data can be saved in persistent storage via Compact Flash and USB interfaces. Also, it does have communications capability via the built-in Ethernet and RS 232/485 interfaces

2.1 Front View of WinCon8000

The following figure demonstrates the hardware system of WinCon8000. it includes the main controller with HMI, serial communication, FR net interface and I/O expansion interface.

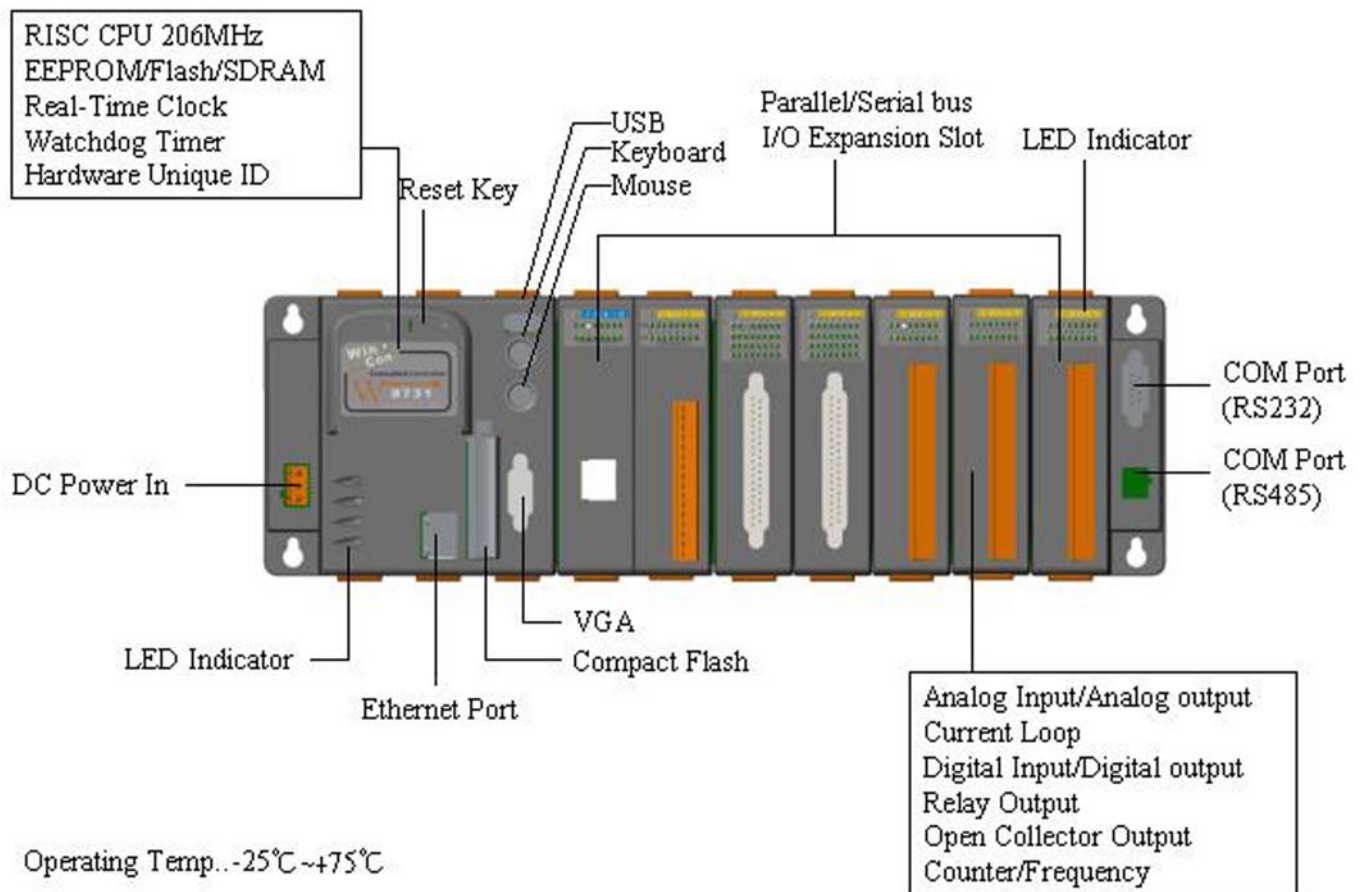

2.2 Specifications

Main Control Unit

- Intel Strong ARM CPU, 206MHz
- SRAM: 64M bytes
- Flash Memory: 32M bytes
- EEPROM: 16K bytes
- 64-bit hardware unique serial number
- Built-in Watchdog Timer
- Real Time Clock
- 10 Base T: NE2000 compatible
- 1 VGA port:
320x240x16 to 1024x768x16
Default is 640x480x16
- 2 PS/2 port: Keyboard and Mouse
- 1 Compact Flash slot: CF memory card
- 1 USB 1.1 Host: USB drive or USB mouse
- Reset button
- Power LEDs

Cabinet

- COM0: Internal use
 - COM1: Serial Control for 87K Series
 - COM2: RS-232
 - COM3: RS-485
 - FRnet(Optional)
 - I/O Expansion Slot:
3-slot for W-8331
7-slot for W-8731
 - Power Supply: 20W, Unregulated +10Vdc to +30Vdc
 - Environment:
Operating Temp.: -25 °C to +75 °C
Storage Temp.: -30 °C to +85 °C
 - Humidity: 5~95%
 - Dimensions:
418x110x75.5mm(7 slot)
418x110x75.5mm(3 slot)
 - I/O module (optional)
I-8000 serial modules, which include DI, DO, AO, AI...
I-87K serial modules, which include DI, DO, AO, AI...
I-7000 serial modules, which include DI, DO, AO, AI...
- For more information, please refer to the relative catalog or <http://www.icpdas.com>.

3. Applications

The following figure shows the general application area and structure. Com2 is the standard RS232 interface, which can be connected with modem. And Com3 is the RS-485 interface, which can be applied to controller ICPDAS DCON serial modules, I-7000, I-8000, I-87K. FRnet system is a optional control interface.

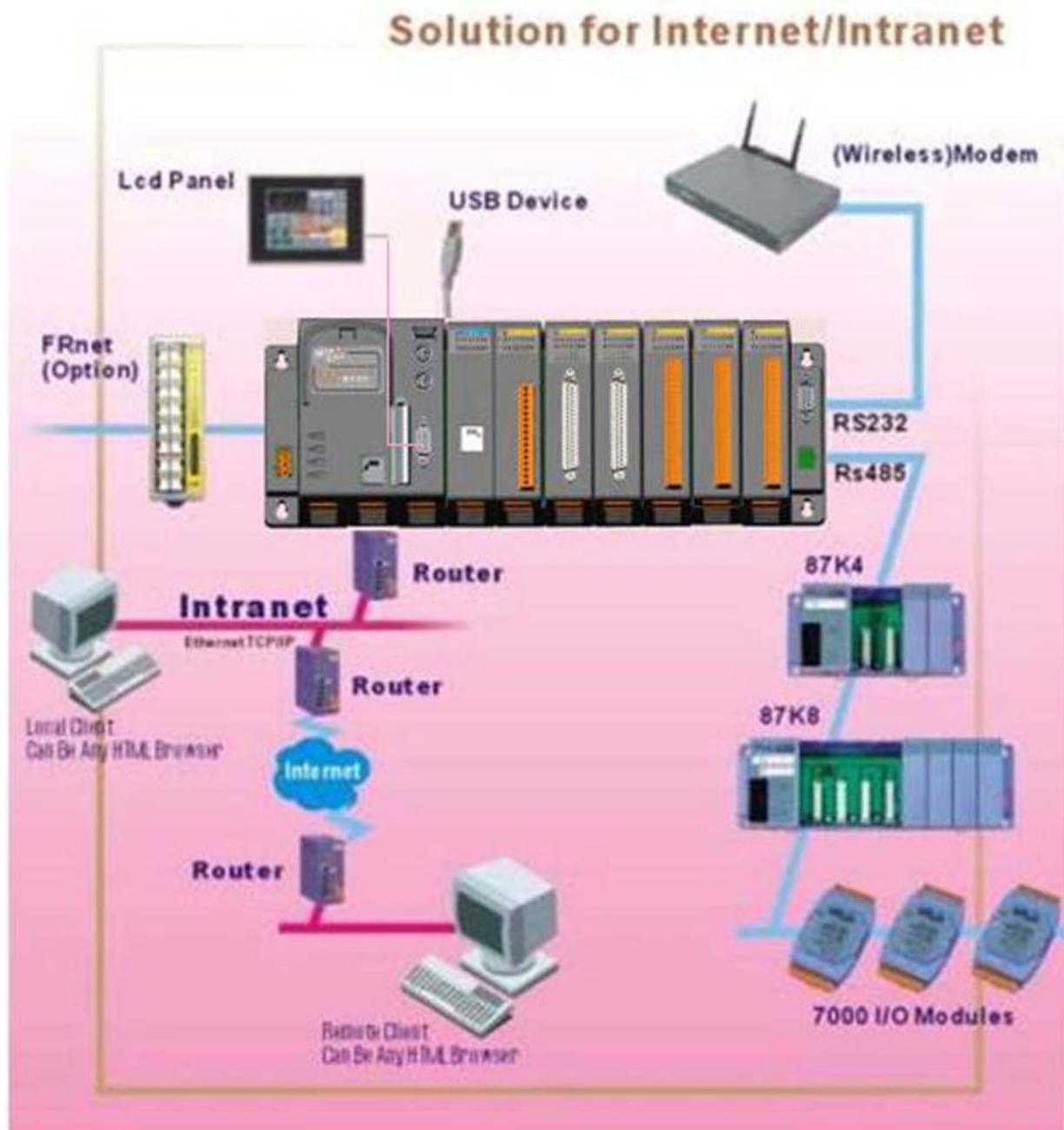

4. Quick Start

Step 1. Insert the bundled CF memory card into the CF slot.

Step 2. Plug in your PS/2 keyboard and mouse.

Step 3. Plug in your VGA monitor.

Step 4. Connect your WinCon8000 to LAN

Step 5. Insert your 8K/87K series I/O modules in slots of expansion cabinet.

Step 6. Connect your COM ports in cabinet to your devices controlled by WinCon8000.

Step 7. Connect to DC power and then turn it on.

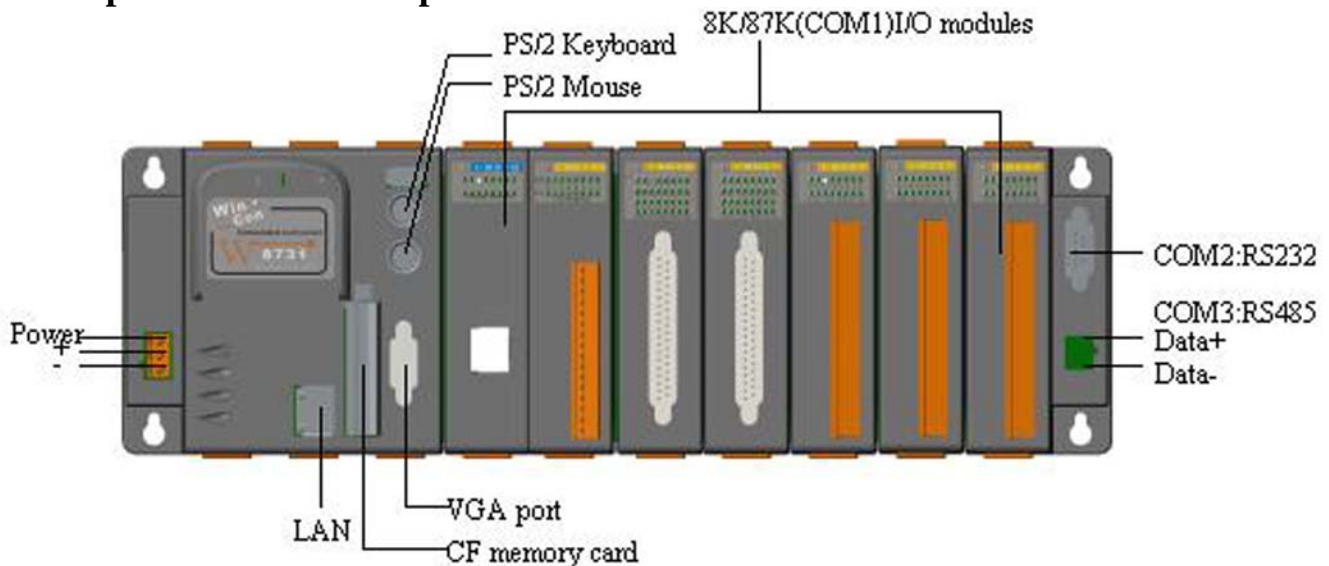

Step 8. The Windows CE .NET starts up, then please refer to the software user's manual for further operations and developing your own applications.

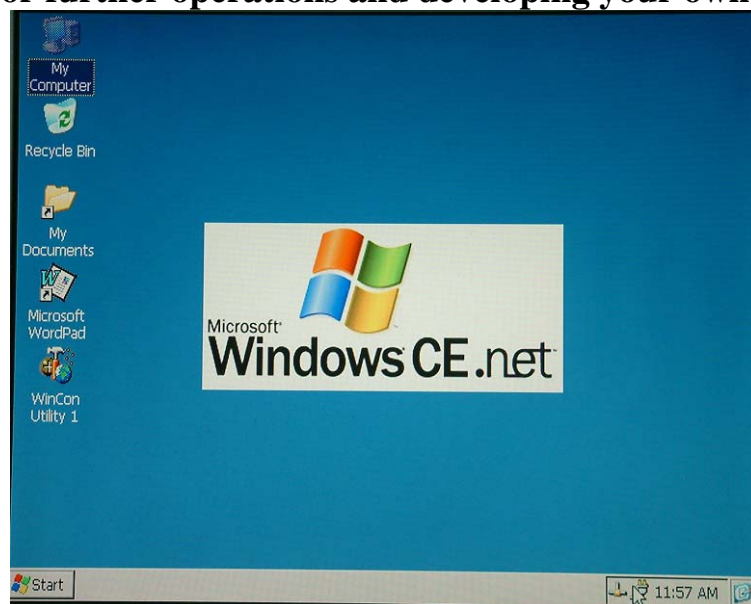

5. Mechanical Information

5.1 Dimensions

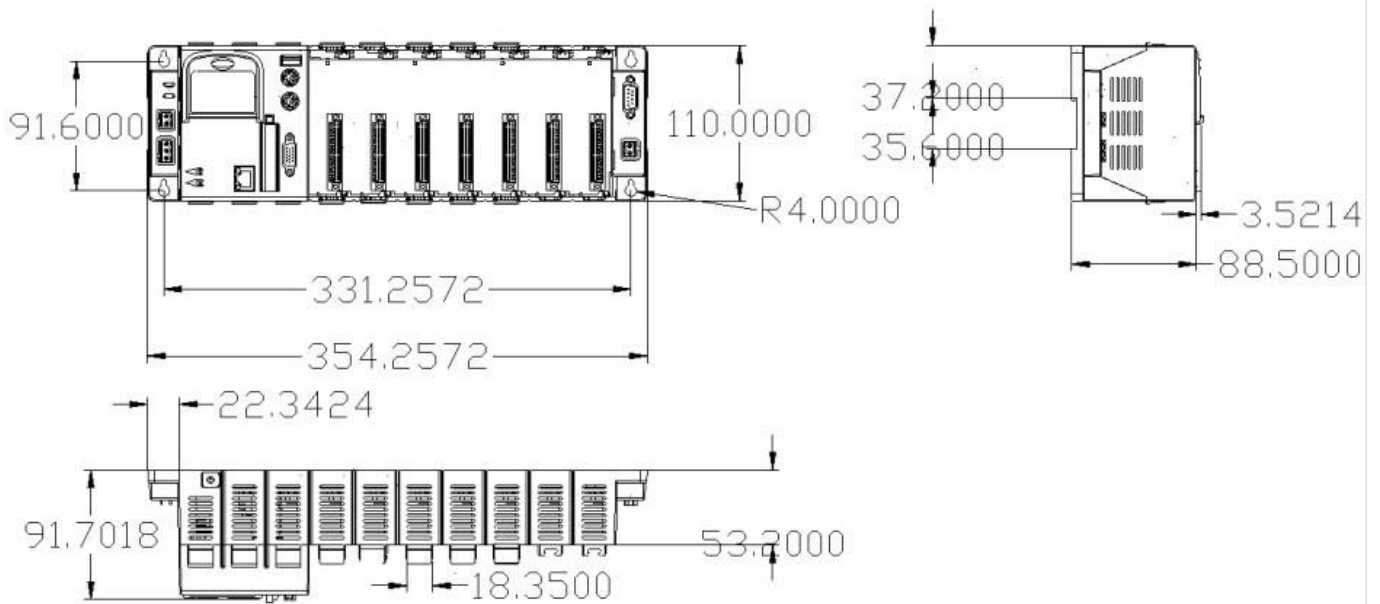

5.2 Dimensions Rail Mounting



5.3 Wall Mounting

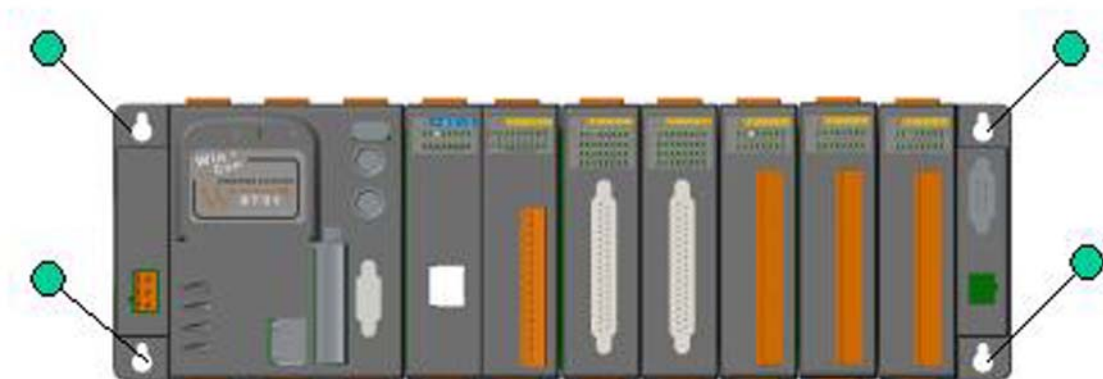

5.4 Controller cover

For safety and controller setting memo, WinCon8000 provides a main controller cover to protect the reset push button to be applied under the uncontrolled situation. And it also offers a expansion slot setting record area and others configuration memo area. The operation procedure is as below:

Step 1: Use hand to push the main controller cover and then pull-down the cover.

Step 2: Open the cover, as shown in the below figure.

The Expansion I/O setting record is right on the main controller unit. And the memo area is on the inside cover, as shown in below. Note that the reset key is on the right-up corner protected by the controller cover.

