

**EBC 552 series**  
**Embedded Controller**

**User's Guide**

*All brand names are registered trademarks of their owners.*

@Copyright 2000

All Rights Reserved

Manual edition 1.04, July 10, 2000

The information in this document is subject to change without prior notice in order to improve reliability, design and function and does not represent commitment on the part of the manufacturer.

In no event will the manufacturer be liable for direct, indirect, special, incidental, or consequential damages arising out of the use or the possibility of such damages.

This document contains proprietary information protected by copyright. All rights are reserved. No part of this manual may be reproduced by any mechanical, electronic, or other means in any form without prior written permission of the manufacturer.

### **Trademarks**

EBC 552 series are registered trademarks of Nexcom International Co., Ltd., IBM PC is a registered trademark of International Business Machines Corporation. Intel and Pentium are registered trademarks of Intel Corporation. Award is a registered trademark of Award Software, Inc. Other product names mentioned herein are used for identification purposes only and may be trademarks and/or registered trademarks of their respective companies.

# Table of Contents

## How to Use This Guide

### Chapter 1. Introduction

1.1 Specifications.....	.. 1-3
1.2 What you have.....	... 1-6

### Chapter 2. Switches and Connectors

2.1 Switch Setting.....	.. 2-1
2.2 Connectors vs. Functions .....	.2-6

### Chapter 3. Capability Expanding

3.1 System Memory.....	.. 3-1
3.2 Cache Memory .....	... 3-2
3.3 Change CPU .....	. 3-3

### Chapter 4. EBC 552 Award BIOS Setup

4.1 Entering Setup.....	.. 4-1
4.2 Control Keys.....	4-2
4.3 Getting Help.....	.. 4-3
4.4 The Main Menu.....	.. 4-4
4.5 Standard CMOS Setup Menu.....	.. 4-6
4.6 BIOS Features Setup Menu.....	4-9
4.7 Chipset Features Setup Menu.....	. 4-15
4.8 Power Management Setup.....	. 4-19
4.9 PnP/PCI Configuration.....	. 4-23
4.10 Integrated Peripherals.....	. 4-25
4.11 Supervisor/User Password Setting.....	. 4-27
4.12 IDE HDD Auto Detection.....	. 4-28
4.13 Hard Disk Low Level Format Utility	4-31
4.14 Power-On Boot.....	. 4-33
4.15 BIOS Reference-POST Message.....	. 4-34
4.16 BIOS Reference-POST Codes.....	. 4-38
4.17 BIOS Default Drive Table.....	. 4-45

### Appendix 1 Watch Dog Timer

### Appendix 2 Memory Mapping

# How to use this guide

This manual is written to help you use EBC 552 series. The manual describes how to arrange various settings on the Intel Pentium MMX/Socket 370 CPU board to meet your requirements. It is briefed as follows:

**Chapter 1**, "Introduction" gives an overview of the product specifications. It also tells you what are included in the product package.

**Chapter 2**, "Switches and Connectors" describes the definitions and positions of Switches and Connectors that you may easily configure and set up per your requirement.

**Chapter 3**, "Capability Expanding" describes how to change or expand the CPU Board by changing the system memory, cache memory, and CPU to get more power out from the CPU board.

**Chapter 4**, "Award BIOS Setup" describes how to use the advanced PCI/Green BIOS to control almost every feature of the EBC 552 series, including the on board SCSI and watchdog timer.

**The Appendix 1** describes how to set up the Watch Dog Timer (WDT) and gives an example to program the WDT.

**The Appendix 2** describes the memory mapping for user reference in add-on card or programming.

## Chapter 1

### **Introduction**

Welcome to the EBC 552 series Pentium/Socket 7 Embedded Controller.

The EBC 552 series is a brand new generation of proven technologies. It's built with high performance, cost effective Pentium/Socket 7 CPU up to 400 MHz, high performance PCI Bus and I/O's, huge memory support (128MB), and support the Intel low power CPU. It is excellent to the system integrators, VARs, or turnkey vendor demanding high performance computing, high performance I/O, high data availability, or any Embedded solutions like kiosk, panel computing, etc.

The EBC 552 series can run with Intel Pentium MMX processor up to 233 MHz, the low power Pentium MMX to 266 MHz, AMD K6-2 up to 400 MHz, memory support up to 128 MB SDRAM. This generates great computing power. The on board enhanced PCI IDE interface can support up to mode 4 PIO and Mode 2 DMA master also support the Ultra DMA 33. The on board PCI board audio module makes the EBC552 an ideal computer for any embedded multimedia applications.

The new C&T 69000 VGA Controller with 2MB embedded SDRAM could supports both CRT and Panel displays. The Intel single chip 82559 Ethernet Controller supports 10 Base T/ 100 Base TX, full Duplex. So the EBC 552 is integrated with all the popular features as the much options for the system integrations.

The dual super I/O integrates the floppy controller, four serial ports, one parallel port, and keyboard/mouse controller. The four on-chip UARTs are compatible with NS 16C550. One out of the 4 serial ports could be set as the 4 RS422/485 interface, and the parallel port support EPP/ECP.

The flash ROM is used to make the BIOS update easier. This product for flexible connections also supports the Universal Serial Bus (USB). The high precision real time clock/calendar is built in for accurate scheduling and the watchdog timer is also the standard feature. The PC104 connector and the standard PCI slot is reserved for future upgrade.

## **1-1 Specifications**

- **System Architecture**
  - Mini board with standard 5.25" drive form factor
  - Intel 430TX PCI set
  - Support all socket 7 CPU up to 400 MHz
  - PCI V2.1 complied
- **CPU Support**
  - Intel Pentium MMX CPU up to 266 MHz, AMD K6-2 CPU support up to 400 MHz
  - Support the low power Pentium MMX 166/266 MHz CPU
  - Support 66 MHz CPU clock
- **Cache Memory**
  - 512KB Pipeline Burst SRAM
- **Main Memory**
  - EDO/SDRAM memory support
  - Up to 128MB (Max.)
  - 168 pin DIMM socket ×1
- **BIOS**
  - Award System BIOS
  - Plug & Play support
  - Advanced Power Management support
  - Advanced Configuration & Power Interface support
  - 2M bits flash ROM
- **Chip Set**
  - Intel 82430TX PCI set
  - PCI V2.1 complied

- **On Board VGA**

- C&T 69000 VGA controller
- TFT LCD/DSTN LCD/CRT control
- 2MB SDRAM on die
- Maximum Res. Color & Refresh Rate

Resolution	Colors	Refresh Rate (Hz)
1280×1024	256	60
1024×768	16bits (High color)	85, 75, 60
800×600	24bits (True color)	85, 75, 60

- Drivers support : Windows 95/98, Windows NT4.0
- 16 pin Box header connector ×1, 50 pin LCD connector ×1

- **On Board LAN**

- Intel 82559 Single Ethernet controller
- 10 Base T/100 Base TX support, full duplex
- Complied with PCI V2.1, IEEE802.3, IEEE 802.3U
- Backward compatible with former 82558 Ethernet controller base net modules
- Drivers support: : DOS/Windows, Windows 95/98, Windows NT4.0, Netware, SCO Open Server 5.0
- RJ45 connector ×1

- **On Board Audio**

- ESS ES1989 Allegro PCI Audio
- Integrated high-fidelity AC 7 codec
- Support multi-stream DirectSound and DirectSound 3D audio technology
- Support standard PCI 2.1 and 2.2 bus
- Driver support : DOS/Windows95/98, Windows NT4.0
- 14 pin integrated connector ×1 (for MIC, Line in, Line out, Mono out, Phone out)

- **On Board I/O**

- SMSC 37C669 & Winbond W83977 Super I/O on board
- SIO ×4, with 4×16C550 UARTs, 40 pin integrated connector ×1, optional

RS422/485 ×1

- PIO ×1, Bi-directional, EPP/ECP support, 26 pin ×1
- Floppy Disk controller : 5.25" 360K/1.2MB, 3.5" 720K/1.2MB/1.44MB/2.88MB support, 34 pin connector ×1
- On chip enhanced IDE ×1, PIO up to mode 4, DMA master up to mode 2, Ultra DMA/33 support, 44 pin ×1, total 2 E.IDE Devices support
- On chip keyboard, mouse controller, PS/2 Keyboard, mouse, 4 ×2 pin integrated connector ×1
- On board USB port ×2 (4 ×2 pin header ×1)
- IrDA pin reserved
- On board buzzer ×1
- On board 2 pin header for reset SW, 4 pin for speaker, 5 pin for keylock
- **On Board RTC**
  - High precision real time clock/calendar with battery back up
- **On Board Solid State Disk Socket**
  - On board reserved socket for DOC of M-systems : 2MB~144MB, etc
- **System Monitor**
  - Winbond W83782D system monitor controller
  - Six voltage (For +5V, -5V, +12V, -12V, 5V stand by and Vcore )
  - One Fan speed (For CPU)
  - One temperature
  - Drivers support: Windows 95/98, Windows NT4.0
- **Standard PCI Slot**
  - One 32 bit standard PCI slot on board for expansion
- **On Board PC104 Expansion**
  - One 16 bit PC104 connector on board
- **Watchdog Timer**
  - 1,2,4 4 seconds time-out intervals
- **Dimensions**
  - 203mm(L) × 146mm(W)

- **Power Requirements**

- +5V : 10A (Max.)
- +12V: 500mA (Max.)
- +3.3V: 5A (Max.)

- **Environments**

- Operating temperatures : 0°C to 60°C
- Storage temperatures : -20°C to 80°C
- Relative humidity : 10% to 90% (Non-condensing)

- **Certification**

- CE approval
- FCC Class A

## **1-2 What you'll have from the package**

In addition to this manual, the EBC 552 series package includes the following items

- EBC 552 series embedded controller x 1
- IDE cable x 1
- FDC cable x 1
- VGA cable x 1
- SIO cable x 1
- PIO cable x 1
- USB cable x 1
- PS2 Y cable x 1
- Audio cable x 1
- CD Disk x 1 (for VGA/LAN/Audio/HW Monitor driver)

If any of these items is missed or damaged, please contact your vendor for what you want.

## Chapter 2

### Switches and Connectors

This chapter gives the definitions and shows where to locate the positions of switches and connectors.

#### 2-1 Switches

Switches on the CPU board are used to select options for different functions used. The switch is to accommodate the variations of the following table.

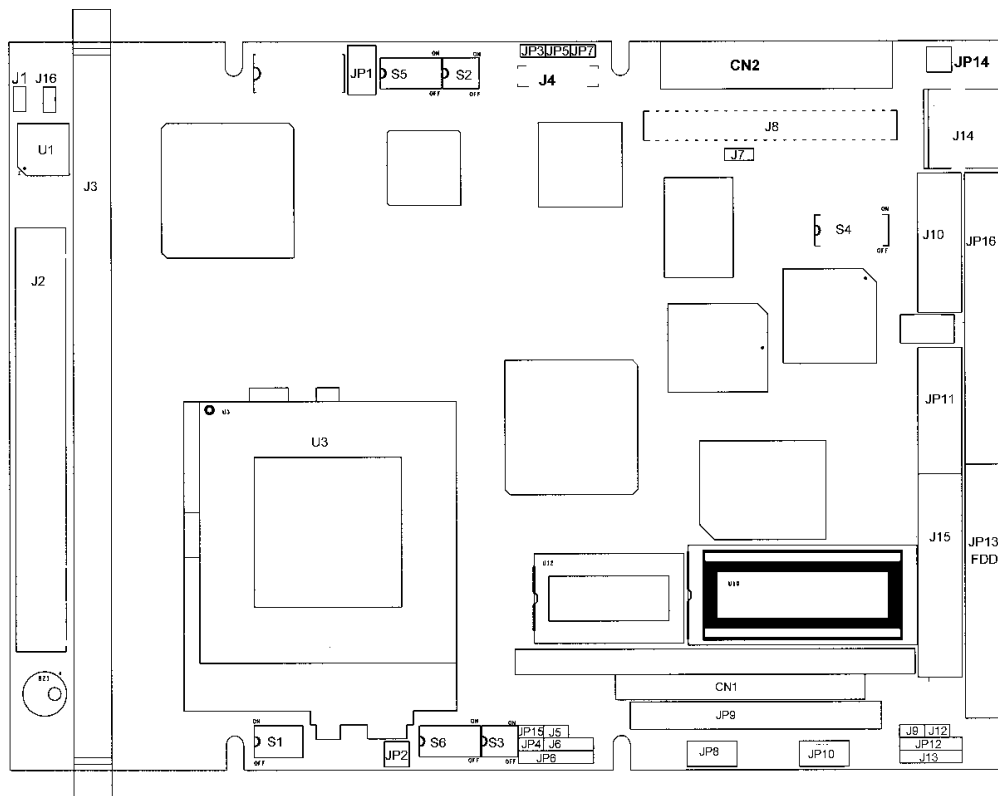

Figure 2-1 Switches and Connectors Positions

**Switch Setting Table (\*default setup)***Bus/Core Freq. Ratio Table***For INTEL Processor**

Ratio	S6.1	S6.2	S6.3	S6.4	S6.5	S6.6	S6.7	S6.8
1.5X	ON	OFF	ON	OFF	----	----	----	----
2.0X	OFF	ON	ON	OFF	OFF	ON	----	----
*2.5X	OFF	ON	OFF	ON	OFF	ON	----	----
3.0X	ON	OFF	OFF	ON	OFF	ON	----	----
3.5X	ON	OFF	ON	OFF	OFF	ON	----	----
4.0X	OFF	ON	OFF	ON	ON	OFF	----	----

**For AMD Processor**

Ratio	S6.1	S6.2	S6.3	S6.4	S6.5	S6.6	S6.7	S6.8
2.0X	OFF	ON	ON	OFF	----	----	ON	OFF
2.5X	OFF	ON	OFF	ON	----	----	ON	OFF
3.0X	ON	OFF	OFF	ON	----	----	ON	OFF
3.5X	ON	OFF	ON	OFF	----	----	ON	OFF
4.0X	OFF	ON	ON	OFF	----	----	OFF	ON
4.5X	OFF	ON	OFF	ON	----	----	OFF	ON
5.0X	ON	OFF	OFF	ON	----	----	OFF	ON
5.5X	ON	OFF	ON	OFF	----	----	OFF	ON
6.0X	OFF	ON	ON	OFF	----	----	ON	OFF

**Clock Freq. (MHz)**

<b>CPU</b>	<b>50.0</b>	<b>75.0</b>	<b>83.3</b>	<b>68.5</b>	<b>83.3</b>	<b>75.0</b>	<b>60.0</b>	<b>*66.8</b>
<b>PCI</b>	<b>25.0</b>	<b>32.0</b>	<b>41.65</b>	<b>34.25</b>	<b>33.3</b>	<b>37.5</b>	<b>30.0</b>	<b>33.4</b>
S5.1	ON	ON	ON	ON	OFF	OFF	OFF	OFF
S5.2	ON	ON	OFF	OFF	ON	ON	OFF	OFF
S5.3	ON	OFF	ON	OFF	ON	OFF	ON	OFF

**SDRAM Refresh Rate (MHz)**

	60	*66
S5.6	ON	OFF

**CPU Vcore Voltage**

Vcore	S1.1	S1.2	S1.3	S1.4	S1.5
Low power CPU (1.9V)	ON	ON	ON	OFF	OFF
AMD K6-II (2.2V)	OFF	OFF	OFF	ON	OFF
AMD K6 (2.4V)	OFF	OFF	ON	OFF	OFF
*INTEL P-55 (2.8V)	OFF	ON	OFF	OFF	OFF
INTEL P-54 (3.3V)	OFF	ON	ON	OFF	ON

**Panel Type**

1	1024x768 dual scan STN color panel
2	1280x1024 TFT color panel
3	640x480 dual scan STN color panel
4	800x600 dual scan STN color panel
5	640x480 sharp TFT color panel
6	640x480 18 bit TFT color panel
7	1024x768 TFT color panel
8	800x600 TFT color panel
9	800x600 TFT color panel
10	800x600 TFT color panel
11	800x600 dual scan STN color panel
12	800x600 dual scan STN color panel
13	1024x768 TFT color panel
14	1280x1024 dual scan STN color panel
15	1024x600 dual scan STN color panel
16	1024x600 TFT color panel

**Panel Type SW**

Type	1	2	3	4	5	6	7	8
S2.1	On	Off	On	Off	On	Off	On	Off
S2.2	On	On	Off	Off	On	On	Off	Off
S2.3	On	On	On	On	Off	Off	Off	Off
S2.4	On	On	On	On	On	On	On	On
Type	9	10	11	12	13	14	15	16
S2.1	On	Off	On	Off	On	Off	On	Off
S2.2	On	On	Off	Off	On	On	Off	Off
S2.3	On	On	On	On	Off	Off	Off	Off
S2.4	Off	Off	Off	Off	Off	Off	Off	Off

**Panel voltage select**

J7	Type
1—2	For 5V Panel
*2—3	For 3V Panel

**CPU Vio control**

CPU	JP2
*INTEL (P-55 or low power CPU) or AMD K6 CPU	Short
INTEL P-54 CPU	Open

**CPU Vio Voltage**

Vio	S1.6
INTEL low power CPU (Vio :2.5V)	OFF
*INTEL P-55 or AMD K6 CPU (Vio:3.3V)	ON

**DiskonChip Configuration Table**

Active Address	S3.1	S3.2	S3.3
*Disable	ON	----	----
C0000	OFF	OFF	OFF
C8000	OFF	OFF	ON
D0000	OFF	ON	OFF
D8000	OFF	ON	ON

**Bios Protect**

Protect	S3.4
Disable	ON
*Enable	OFF

**Disable LAN/Audio Function Switch**

Type	S5.8	S5.7
*LAN-Enable & Audio-Enable	ON	ON
LAN-Disable & Audio-Enable	OFF	ON
LAN-Disable & Audio-Disable	OFF	OFF
LAN-Enable & Audio- Disable	ON	OFF

**Com4 Mode Table (RS232, RS422, RS485):**

<b>Mode</b>	<b>S4.1</b>	<b>S4.2</b>	<b>S4.3</b>	<b>S4.4</b>	<b>S4.5</b>
*RS232	OFF	OFF	OFF	ON	OFF
RS422	OFF	ON	ON	OFF	ON
RS485	ON	ON	OFF	ON	ON
<b>Mode</b>	<b>S4.6</b>	<b>S4.7</b>	<b>S4.8</b>	<b>S4.9</b>	<b>S4.10</b>
*RS232	ON	OFF	OFF	OFF	OFF
RS422	OFF	ON	ON	ON	ON
RS485	OFF	ON	ON	ON	ON

**Connectors vs. Functions****Connector Position**

<b>Connector</b>	<b>Function</b>
J1	Temperature
J2	External PCI Connector
J5	Power button
J6	External Buzzer Connector
J7	Jumper for Panel Power select
J8	Panel Connector
J9	IDE LED
J10	CRT Connector
J11	CD IN connector
J12	Reset Button
J13	IR Connector
J14	RJ45
J15	Parallel Connector
J16	SM BUS
JP1	Fan Connector
JP2	Vio Jumper short
JP3	Link LED
JP4	RTC Reset Jumper
JP5	Active LED
JP7	Speed LED
JP8	USB Connector
JP9	IDE Connector
JP10	KB. /MS. Connector
JP11	Audio Connector
JP12	Keyboard Lock
JP13	FDD Connector
JP14	GPIOX2
JP15	Power LED
JP16	COM1, COM2, COM3, COM4 Connector
CN1	PC 104 Connector
CN2	ATX Power Connector

**Pin Definition:****J1: TEMPERATURE**

PIN No.	Description
1	SENSE
2	GND

**J2: PCI CONNECTOR**

PIN NO.	DESCRIPTION	PIN NO.	DESCRIPTION
B1	-12V	A1	GND
B2	GND	A2	+12V
B3	GND	A3	+5V
B4	N/C	A4	+5V
B5	+5V	A5	+5V
B6	+5V	A6	INTA-
B7	INTB-	A7	INTC-
B8	INTD-	A8	+5V
B9	GND	A9	CLKRUM
B10	REQ0	A10	+5V
B11	GND	A11	N/C
B12	GND	A12	GND
B13	GND	A13	GND
B14	CLK2	A14	GNT1
B15	GND	A15	RESET
B16	CLK1	A16	+5V
B17	GND	A17	GNT2
B18	REQ2	A18	GND
B19	+5V	A19	N/C
B20	AD31	A20	AD30
B21	AD29	A21	+3.3V
B22	GND	A22	AD28
B23	AD27	A23	AD26
B24	AD25	A24	GND
B25	+3.3V	A25	AD24
B26	C/BE3-	A26	IDSEL
B27	AD23	A27	+3.3V
B28	GND	A28	AD22
B29	AD21	A29	AD20

B30	AD19	A30	GND
B31	+3.3V	A31	AD18
B32	AD17	A32	AD16
B33	C/BE2-	A33	+3.3V
B34	GND	A34	FRAME-
B35	IRDY-	A35	GND
B36	+3.3V	A36	TRDY-
B37	DEVSEL-	A37	GND
B38	GND	A38	STOP-
B39	LOCK-	A39	+3.3V
B40	PERR-	A40	SDON
B41	+3.3V	A41	SBO
B42	SERR-	A42	GND
B43	+3.3V	A43	PAR
B44	C/BE1-	A44	AD15
B45	AD14	A45	+3.3V
B46	GND	A46	AD13
B47	AD12	A47	AD11
B48	AD10	A48	GND
B49	GND	A49	AD09
B52	AD08	A52	C/BE0-
B53	AD07	A53	+3.3V
B54	+3.3V	A54	AD06
B55	AD05	A55	AD04
B56	AD03	A56	GND
B57	GND	A57	AD02
B58	AD01	A58	AD00
B59	+5V	A59	+5V
B60	ACK64-	A60	REQ64-
B61	+5V	A61	+5V
B62	+5V	A62	+5V

**J5: POWER BUTTON**

PIN No.	Description
1	Power On
2	3VSB

**J6: SPEAKER**

PIN No.	Description
1	Speaker Signal
2	GND
3	GND
4	+5V

**J7: PANEL VOLTAGE SELECT**

PIN No.	Description
1-2	For 5V Panel
2-3	For 3V Panel

**J8: PANEL CONNECTOR**

PIN No.	Description	PIN No.	Description
1	ENABKL	2	+12V SAFE
3	LP	4	DE
5	SHFCLK	6	FLM
7	PO	8	VDDSAFE
9	P2	10	P1
11	P4	12	P3
13	P6	14	P5
15	P8	16	P7
17	P10	18	P9
19	P12	20	VDDSAFE
21	P14	22	P11
23	GND	24	P13
25	P16	26	P15
27	P18	28	P17
29	P20	30	ENAVEE
31	P22	32	P19
33	GND	34	P21
35	P24	36	P23
37	P26	38	P25
39	M/PCLK	40	GND
41	P28	42	P27
43	P30	44	P29
45	P32	46	P31
47	P34	48	P33

49	GND	50	P35
----	-----	----	-----

**J9: IDE LED CONNECTOR**

PIN No.	Description
1	+5V
2	HDD Active #

**J10: CRT CONNECTOR**

PIN No.	Description
1	RED
2	Green
3	Blue
4	NC
5	GND
6	GND
7	GND
8	GND
9	+5
10	GND
11	NC
12	Display Data channel data
13	Horizontal Sync
14	Vertical Sync
15	Display Data Channel CLK
16	GND

**J11: CD IN CONNECTOR**

Pin No	Description
1	CD in L
2	GND
3	CD in R
4	GND

**J12: RESET BUTTON**

Pin No.	Description
1	Reset
2	GND

**J13: IR CONNECTOR**

Pin No.	Description
1	+5V
2	FIR
3	IRRX
4	GND
5	IRTX

**J14: LAN CONNECTOR**

Pin No.	Description
1	TX+
2	TX-
3	RX+
4	GND
5	GND
6	RX-
7	GND
8	GND

**J15: PARALLEL CONNECTOR**

Pin No.	Description	Pin No.	Description
1	Strobe#	2	Data 0
3	Data 1	4	Data 2
5	Data 3	6	Data 4
7	Data 5	8	Data 6
9	Data 7	10	Acknowledge
11	Busy	12	Paper Empty
13	Printer Select	14	Auto Form Feed#
15	Error#	16	Initialize
17	Printer Select IN#	18	GND
19	GND	20	GND
21	GND	22	GND
23	GND	24	GND
25	GND	26	GND

**J16: I<sup>2</sup>C CONNECTOR**

Pin No.	Description
1	SMBCLK

2	SMBDATA
---	---------

**JP1: FAN POWER CONNECTOR**

Pin No.	Description
1	GND
2	+12V
3	Sense

**JP2: VIO JUMPER SHORT**

Pin No.	Description
1	Power In
2	Power Out
3	Power In
4	Power Out

**JP3: LAN LINK LED**

Pin No.	Description
1	3VSB
2	LINK

**JP4: RTC RESET JUMPER**

Pin No.	Description
1	RTC Clear
2	GND

**JP5: LAN ACTIVE LED**

Pin No.	Description
1	3VSB
2	Active

**JP7: LAN SPEED LED**

Pin No.	Description
1	3VSB
2	Speed

**JP8: USB CONNECTOR CHANNEL 1. & CHANNEL 2.**

Pin No.	Description
1/5	+5V
2/6	-Data 0
3/7	+Data 0
4/8	GND

**JP9: IDE INTERFACE CONNECTOR**

Pin No.	Description	Pin No.	Description
1	Reset #	2	GND
3	Data 7	4	Data 8
5	Data 6	6	Data 9
7	Data 5	8	Data 10
9	Data 4	10	Data 11
11	Data 3	12	Data 12
13	Data 2	14	Data 13
15	Data 1	16	Data 14
17	Data 0	18	Data 15
19	GND	20	N/C
21	DMA REQ	22	GND
23	IOW	24	GND
25	IOR	26	GND
27	IOCHRDY	28	Pull Down
29	DMA ACK	30	GND
31	Interrupt 14	32	N/C
33	Disk Address 1	34	N/C
35	Disk Address 0	36	Disk Address 2
37	HDC CS100	38	HDC CS300
39	HDD Active Led	40	GND
41	+5V	42	+5V
43	GND	44	GND

**JP10: KEYBOARD AND MOUSE CONNECTOR**

Pin No.	Description
1	+5V
2	KB_DATA
3	KB_CLK
4	GND
5	+5V
6	MS_DATA
7	MS_CLK
8	GND

**JP11: AUDIO CONNECTOR**

Pin No.	Descriptions	Pin No.	Descriptions
1	GND	8	GND
2	MONO-OUT (Yellow)	9	Line in R (White)
3	GND	10	Line in L (White)
4	Phone	11	GND
5	GND	12	GND
6	Mic. (Red)	13	Line out R (Black)
7	+5V	14	Line out L (Black)

**Note:** Please refer to the definition of the connectors.

Yellow: MONO-OUT Connector

Red: Mic Connector

White: Line in Connector

Black: Line out Connector

**JP12: KEYBOARD LOCK**

PIN No.	Description
1	GND
2	KB LOCK
3	GND
4	N/C
5	+5V

**JP13: FDD CONNECTOR**

<b>PIN No.</b>	<b>Description</b>	<b>PIN No.</b>	<b>Description</b>
1	GND	2	Density Select
3	GND	4	N/C
5	GND	6	N/C
7	GND	8	Index#
9	GND	10	Motor Enable A#
11	GND	12	Drive Select B#
13	GND	14	Drive Select A#
15	GND	16	Motor Enable B#
17	GND	18	Direction#
19	GND	20	Step#
21	GND	22	Write Data#
23	GND	24	Write Gate#
25	GND	26	Track 0#
27	GND	28	Write Protect#
29	N/C	30	Read Data#
31	GND	32	Head Side Select#
33	N/C	34	Disk Change#

**JP14: GPIO CONNECTOR**

<b>Pin No.</b>	<b>Description</b>	<b>Pin No.</b>	<b>Description</b>
1	GPIA	2	GPOA
3	GPIB	4	GPOB

**JP15: POWER LED**

<b>Pin No.</b>	<b>Description</b>
1	+5V
2	GND

**JP16: SERIAL PORT CONNECTOR**

<b>Pin No.</b>	<b>Description</b>	<b>Pin No.</b>	<b>Description</b>
1	RS232 (DCD1)	21	RS232 (DCD3)
2	RS232 (RXD1)	22	RS232 (RXD3)
3	RS232 (TXD1)	23	RS232 (TXD3)
4	RS232 (DTR1)	24	RS232 (DTR3)
5	GND	25	GND
6	RS232 (DSR1)	26	RS232 (DSR3)
7	RS232 (RTS1)	27	RS232 (RTS3)
8	RS232 (CTS1)	28	RS232 (CTS3)
9	RS232 (RI1)	29	RS232 (RI3)
10	GND	30	GND
11	RS232 (DCD2)	31	RS232 (DCD4)/RS422 (TXD+)
12	RS232 (RXD2)	32	RS232 (RXD4)/RS422 (TXD-)
13	RS232 (TXD2)	33	RS232 (TXD4)/RS485 (RXD+)
14	RS232 (DTR2)	34	RS232 (DTR4)/RS485 (RXD-)
15	GND	35	GND
16	RS232 (DSR2)	36	RS232 (DSR4)/RS422 (RTS+)
17	RS232 (RTS2)	37	RS232 (RTS4)/RS422 (RTS-)
18	RS232 (CTS2)	38	RS232 (CTS4)/RS422 (CTS+)
19	RS232 (RI2)	39	RS232 (RI4)/RS422 (CTS-)
20	GND	40	GND

**CN1: PC 104 CONNECTOR**

<b>Pin No.</b>	<b>Description</b>	<b>Pin No.</b>	<b>Description</b>
B1	GND	A1	IOCHK-
B2	RSTISA	A2	SD7
B3	+5V	A3	SD6
B4	IRQ9	A4	SD5
B5	-5V	A5	SD4
B6	DRQ2	A6	SD3
B7	-12V	A7	SD2
B8	ZWS-	A8	SD1
B9	+12V	A9	SD0
B10	GND	A10	IOCHRDY
B11	SMEMW-	A11	AEN
B12	SMEMR-	A12	SA19
B13	IOW-	A13	SA18
B14	IOR-	A14	SA17
B15	DAACK3-	A15	SA16
B16	DRQ3	A16	SA15
B17	DAACK1-	A17	SA14
B18	DRQ1	A18	SA13
B19	REF-	A19	SA12
B20	SYSCLK	A20	SA11
B21	IRQ7	A21	SA10
B22	IRQ6	A22	SA9
B23	IRQ5	A23	SA8
B24	IRQ4	A24	SA7
B25	IRQ3	A25	SA6
B26	DAACK2-	A26	SA5
B27	T/C	A27	SA4
B28	ALE	A28	SA3
B29	+5V	A29	SA2
B30	14.318MHZ	A30	SA1
B31	GND	A31	SA0
B32	GND	A32	GND
D0	GND	C0	GND
D1	MEMCS16-	C1	BHE-
D2	IOCS16-	C2	LA23
D3	IRQ10	C3	LA22

D4	IRQ11	C4	LA21
D5	IRQ12	C5	LA20
D6	IRQ13	C6	LA19
D7	IRQ14	C7	LA18
D8	DACK0-	C8	LA17
D9	DRQ0	C9	MEMR-
D10	DACK5-	C10	MEMW-
D11	DRQ5	C11	SD8
D12	DACK6-	C12	SD9
D13	DRQ6	C13	SD10
D14	DACK7-	C14	SD11
D15	DRQ7	C15	SD12
D16	+5V	C16	SD13
D17	MASTER-	C17	SD14
D18	GND	C18	SD15
D19	GND	C19	GND

**CN2: ATX POWER CONNECTOR**

Pin No.	Description	Pin No.	Description
1	+3V	11	+3V
2	+3V	12	-12V
3	GND	13	GND
4	+5V	14	Power ON
5	GND	15	GND
6	+5V	16	GND
7	GND	17	GND
8	N/C	18	-5V
9	+5Vstandby	19	+5V
10	+12V	20	+5V

## Chapter 3

### **Capability Expanding**

This chapter explains how you can expand capability of your CPU board in such aspects as system memory, cache memory, and CPU.

#### **3-1 System Memory**

Your system memory is provided by DIMM's (Dual In-line Memory Modules) on the CPU board. The CPU board contains two memory banks: Bank 0, 1, corresponds to connector DIMM.

The table below shows possible DIMM configurations for the memory banks and the figure helps you correctly install the DIMM modules. The EBC 552 series supports both EDO memory and SDRAM.

<b>DIMM</b>
16 MB
32 MB
32 MB
64 MB
128 MB

## **Installing DIMM**

To install the DIMM , first make sure the two handles of the DIMM socket are in the open position, i.e. the handles stay outward. Slowly slide the DIMM modules along the plastic guides in the both ends of the socket. Then press the DIMM module down right into the socket, until a click sound is heard. That means the two handles automatically locked the memory modules into the right position of the DIMM socket as Figure 3-1 shows. To take away the memory module, just push the both handles outward, the memory module will be ejected by the mechanism in the socket.

*Figure 3-1 Install DIMM*

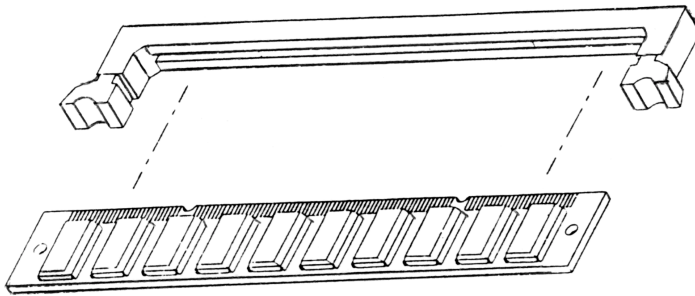

## **3-2 Cache Memory**

The EBC 552 series only support high-speed pipeline burst SRAM. The standard configuration is 64K x 64 for 512KB.

### 3-3 Changes CPU

To change the CPU, pull the handling bar of the socket upward to the other end to loosen the socket's openings. Carefully lift the existing CPU up to remove it from the socket.

*Figure 3-2 Removing CPU*

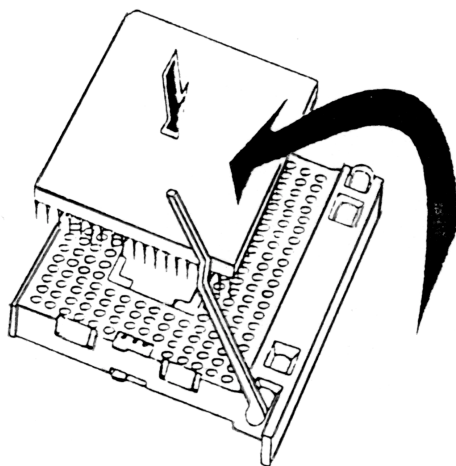

Place the new CPU on the middle of the socket, orienting its beveled corner to line up with the socket's beveled corner. Make sure the pins of the CPU fit evenly to the socket openings. Replace the handling bar to fasten the CPU to the socket. Be sure to re-arrange the jumper setting for the correct clock (S5.1, S5.2, S5.3) and Core/Bus ratio (S5).

*Figure 3-3* Installing CPU

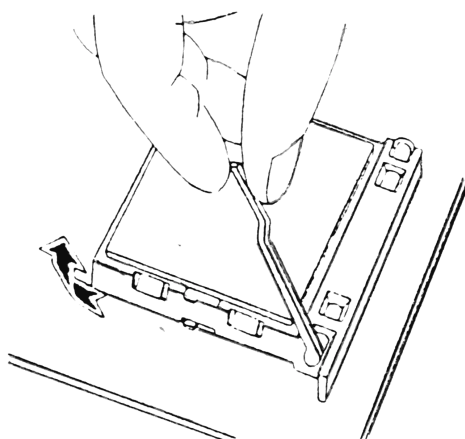

## Chapter 4

# AWARD BIOS Setup

Award's BIOS ROM has a built-in Setup program that allows users to modify the basic system configuration. This type of information is stored in battery-backed RAM (CMOS RAM) so that it retains the Setup information when the power is turned off.

### *Entering Setup*



Power on the computer and press <Del> immediately will allow you to enter Setup. The other way to enter Setup is to power on the computer, when the below message appears briefly at the bottom of the screen during the POST (Power On Self Test), press <Del> key or simultaneously press <Ctrl>, <Alt>, and <Esc> keys.

TO ENTER SETUP BEFORE BOOT PRESS <CTRL-ALT-ESC> OR  
<DEL> KEY

If the message disappears before you respond and you still wish to enter Setup, restart the system to try again by turning it OFF then ON or pressing the "RESET" button on the system case. You may also restart by simultaneously pressing <Ctrl>, <Alt>, and <Delete> keys. If you do not press the keys at the correct time and the system does not boot, an error message will be displayed and you will again be asked to,

PRESS <F1> TO CONTINUE, <CTRL-ALT-ESC> OR <DEL> TO  
ENTER SETUP

## *Control Keys*

Up arrow ↑	Move to previous item
Down arrow ↓	Move to next item
Left arrow →	Move to the item in the left hand
Right arrow ←	Move to the item in the right hand
Esc key	Main Menu -- Quit and not save changes into CMOS Status Page Setup Menu and Option Page Setup Menu -- Exit current page and return to Main Menu
PgUp /  key	Increase the numeric value or make changes
PgDn /  key	Decrease the numeric value or make changes
F1 key	General help, only for Status Page Setup Menu and Option Page Setup Menu
(Shift)F2 key	Change color from total 16 colors. F2 to select color forward, (Shift) F2 to select color backward
F3 key	Reserved
F4 key	Reserved
F5 key	Restore the previous CMOS value from CMOS, only for Option Page Setup Menu
F6 key	Load the default CMOS value from BIOS default table, only for Option Page Setup Menu
F7 key	Load the Setup default, only for Option Page Setup Menu
F8 key	Reserved
F9 key	Reserved
F10 key	Save all the CMOS changes, only for Main Menu

## *Getting Help*

### Main Menu

The on-line description of the highlighted setup function is displayed at the bottom of the screen.

### Status Page Setup Menu/Option Page Setup Menu

Press F1 to pop up a small help window that describes the appropriate keys to use and the possible selections for the highlighted item. To exit the Help Window press <F1> or <Esc>.

## The Main Menu

Once you enter Award BIOS CMOS Setup Utility, the Main Menu (Figure 1) will appear on the screen. The Main Menu allows you to select from ten setup functions and two exit choices. Use arrow keys to select the items and press <Enter> to accept or enter the sub-menu.

ROM PCI/ISA BIOS (E552A-00) CMOS SETUP UTILITY AWARD SOFTWARE, INC.															
<table style="width: 100%; border-collapse: collapse;"> <tr> <td style="border: 1px solid black; padding: 2px;"><b>STANDARD CMOS SETUP</b></td> </tr> <tr> <td style="padding: 2px;"><b>BIOS FEATURES SETUP</b></td> </tr> <tr> <td style="padding: 2px;"><b>CHIPSET FEATURES SETUP</b></td> </tr> <tr> <td style="padding: 2px;"><b>POWER MANAGEMENT SETUP</b></td> </tr> <tr> <td style="padding: 2px;"><b>PNP/PCI CONFIGURATION</b></td> </tr> <tr> <td style="padding: 2px;"><b>LOAD BIOS DEFAULTS</b></td> </tr> <tr> <td style="padding: 2px;"><b>LOAD SETUP DEFAULTS</b></td> </tr> </table>	<b>STANDARD CMOS SETUP</b>	<b>BIOS FEATURES SETUP</b>	<b>CHIPSET FEATURES SETUP</b>	<b>POWER MANAGEMENT SETUP</b>	<b>PNP/PCI CONFIGURATION</b>	<b>LOAD BIOS DEFAULTS</b>	<b>LOAD SETUP DEFAULTS</b>	<table style="width: 100%; border-collapse: collapse;"> <tr> <td style="border: 1px solid black; padding: 2px;"><b>INTEGRATED PERIPHERALS</b></td> </tr> <tr> <td style="padding: 2px;"><b>SUPERVISOR PASSWORD</b></td> </tr> <tr> <td style="padding: 2px;"><b>USER PASSWORD</b></td> </tr> <tr> <td style="padding: 2px;"><b>IDE HDD AUTO DETECTION</b></td> </tr> <tr> <td style="padding: 2px;"><b>HDD LOW LEVEL FORMAT</b></td> </tr> <tr> <td style="padding: 2px;"><b>SAVE &amp; EXIT SETUP</b></td> </tr> <tr> <td style="padding: 2px;"><b>EXIT WITHOUT SAVING</b></td> </tr> </table>	<b>INTEGRATED PERIPHERALS</b>	<b>SUPERVISOR PASSWORD</b>	<b>USER PASSWORD</b>	<b>IDE HDD AUTO DETECTION</b>	<b>HDD LOW LEVEL FORMAT</b>	<b>SAVE &amp; EXIT SETUP</b>	<b>EXIT WITHOUT SAVING</b>
<b>STANDARD CMOS SETUP</b>															
<b>BIOS FEATURES SETUP</b>															
<b>CHIPSET FEATURES SETUP</b>															
<b>POWER MANAGEMENT SETUP</b>															
<b>PNP/PCI CONFIGURATION</b>															
<b>LOAD BIOS DEFAULTS</b>															
<b>LOAD SETUP DEFAULTS</b>															
<b>INTEGRATED PERIPHERALS</b>															
<b>SUPERVISOR PASSWORD</b>															
<b>USER PASSWORD</b>															
<b>IDE HDD AUTO DETECTION</b>															
<b>HDD LOW LEVEL FORMAT</b>															
<b>SAVE &amp; EXIT SETUP</b>															
<b>EXIT WITHOUT SAVING</b>															
<table style="width: 100%; border-collapse: collapse;"> <tr> <td style="width: 50%; padding: 2px;">Esc : Quit</td> <td style="width: 50%; padding: 2px;">↑ ↓ → ← : Select Item</td> </tr> <tr> <td style="padding: 2px;">F10 : Save &amp; Exit Setup</td> <td style="padding: 2px;">(Shift)F2 : Change Color</td> </tr> </table>		Esc : Quit	↑ ↓ → ← : Select Item	F10 : Save & Exit Setup	(Shift)F2 : Change Color										
Esc : Quit	↑ ↓ → ← : Select Item														
F10 : Save & Exit Setup	(Shift)F2 : Change Color														

### **Standard CMOS Setup**

This setup page includes all the items in a standard compatible BIOS. See Page 4-6 to Page 4-8 for details.

### **BIOS Features Setup**

This setup page includes all the items of Award special enhanced features. See Page 4-9 to Page 4-14 for details.

### **Chipset Features Setup**

This setup page includes all the items of chipset special features. See Page 4-15 to 4-18 for details.

### **Power Management Setup**

This category determines how much power consumption for system after selecting below items. Default value is Disable. See Page 4-19 to Page 4-22 for details.

### **PNP/PCI Configuration**

This category specifies the assignment of all the IRQ and DMA . See Page 4-23 to Page 4-24 for details.

### **Load BIOS Defaults**

BIOS defaults indicates the most appropriate value of the system parameter which the system would be in minimum performance. The OEM manufacturer may change the defaults through MODBIN before the binary image burn into the ROM.

### **Load Setup Defaults**

Chipset defaults indicates the values required by the system for the maximum performance. The OEM manufacturer may change to defaults through MODBIN before the binary image burn into the ROM.

### **Integrated Peripherals**

This category allows you to set up all the on board I/O controllers like IDE, SCSI, FDC, etc.,. See Page 4-25 to Page 4-26

### **Supervisor/User Password**

Change, set, or disable password of supervisor or user. It allows you to limit access to the system and Setup, or just to Setup. See Page 4-27 for details.

### **IDE HDD Auto Detection**

Automatically configure hard disk parameters. See Page 4-28 to Page 4-30 for details.

### **HDD Low Level Format**

Hard disk low level format utility.

### **Save & Exit Setup**

Save CMOS value changes to CMOS and exit setup.

### **Exit Without Saving**

Abandon all CMOS value changes and exit setup.

## Standard CMOS Setup Menu

The items in Standard CMOS Setup Menu are divided into 10 categories. Each category includes no, one or more than one setup items. Use the arrow key to highlight the item and then use the <PgUp> or <PgDn> keys to select the value you want in each item.

```
ROM PCI/ISA BIOS (E552A-00)
STANDARD CMOS SETUP
AWARD SOFTWARE, INC.
```

```

Date (mm:dd:yy) : Tue, Apr 18 2000
Time (hh:mm:ss) : 14 : 18 : 56

          CYLS.  HEADS  PRECOMP  LANDZONE  SECTORS  MODE
Drive C :    0 (  0Mb)    0    0    0    0    0    AUTO
Drive D :    0 (  0Mb)    0    0    0    0    0    AUTO

Drive A : 1.44M, 3.5 in.
Drive B : None
Floppy 3 Mode Support : Disabled

LCD&CRT : Auto

Halt On : All Errors
    
```

```

ESC : Quit          ↑ ↓ + + : Select Item      PU/PD/+/- : Modify
F1  : Help          (Shift)F2 : Change Color
    
```

### Date

The date format is <day>, <date> <month> <year>. Press <F3> to show the calendar.

day	The day of week, from Sun through Sat, determined by the BIOS, is read only
date	The date, from 1 through 31 (or the maximum allowed in the month), can key in the numerical /function key
mont h	The month, from Jan through Dec
year	The year, depend on the year of BIOS

### Time

The time format is <hour> <minute> <second>, which accepts either function key or numerical key. The time is calculated based on the 24-hour military-time clock. For example, 1 p.m. is 13:00:00.

## **Primary Master/Primary Slave/Secondary Master/Secondary Slave**

The categories identify the types of 2 channels that have been installed in the computer. There are 45 predefined types and 4 user definable types for enhanced IDE BIOS. Type 1 to Type 45 are predefined. Type User is user-definable.

Press PgUp/<+> or PgDn/<-> to select a numbered hard disk type or type the number and press <Enter>. Note that the specifications of your drive must match with the drive table. The hard disk will not work properly if you enter improper information for this category. If your hard disk drive type is not matched or listed, you can use Type User to define your own drive type manually.

If you select Type User, related information is asked to be entered to the following items. Enter the information directly from the keyboard and press <Enter>. This information should be provided in the documentation from your hard disk vendor or the system manufacturer.

If the controller of HDD interface is ESDI, the selection shall be type 1

If the controller of HDD interface is SCSI, the selection shall be one

If the controller of HDD interface is CD-ROM, the selection shall be one

CYLS.	number of cylinders
HEADS	number of heads
PRECOMP	write precom
LANDZONE	landing zone
SECTORS	number of sectors
MODE	HDD access mode

If a hard disk has not been installed select NONE and press <Enter>.

## **Drive A Type/Drive B Type**

The category identifies the type of floppy disk drive A or drive B that has been installed in the computer.

None	No floppy drive installed
360K, 5.25 in	5-1/4 inch PC-type standard drive; 360 kilobyte capacity
1.2M, 5.25 in	5-1/4 inch AT-type high-density drive; 1.2 megabyte capacity
720K, 3.5 in	3-1/2 inch double-sided drive; 720 kilobyte capacity
1.44M, 3.5 in	3-1/2 inch double-sided drive; 1.44 megabyte capacity

2.88M, 3.5 in	3-1/2 inch double-sided drive; 2.88 megabyte capacity
---------------	---

**Floppy 3 Mode Support:**

The category determines whether the floppy 3 mode support is enabled or not.

**LCD&CRT:**

On board VGA select display type.

Type	Function
CRT	Boot from CRT only
LCD	Boot on LCD only
BOTH	Boot both LCD and CRT
AUTO	Boot on CRT or LCD

**Error Halt On**

The category determines whether the computer will stop or not if an error is detected during power up.

No Errors	Whenever the BIOS detects a non-fatal error the system will be stopped and you will be prompted.
All Errors	The system boot will not be stopped for any error that may be detected.
All, but Keyboard	The system boot will not stop for a keyboard error; it will stop for all other errors.
All, but Diskette	The system boot will not stop for a disk error; it will stop for all other errors.
All, but Disk/Key	The system boot will not stop for a keyboard or disk error; it will stop for all other errors.

## BIOS Features Setup Menu

```

ROM PCI/ISA BIOS (E552A-00)
BIOS FEATURES SETUP
AWARD SOFTWARE, INC.

Virus Warning           : Disabled
CPU Internal Cache     : Enabled
External Cache         : Enabled
Quick Power On Self Test : Disabled
Boot From LAN First    : Disabled
Boot Sequence          : A,C,SCSI
Swap Floppy Drive      : Disabled
Boot Up Floppy Seek    : Disabled
Boot Up NumLock Status : On
Boot Up System Speed   : High
Gate A20 Option        : Normal
Typematic Rate Setting : Disabled
Typematic Rate (Chars/Sec) : 30
Typematic Delay (Msec) : 250
Security Option        : Setup
PCI/UGA Palette Snoop : Disabled
OS Select For DRAM > 64MB : Non-OS2
HDD S.M.A.R.T. capability : Disabled

Video BIOS Shadow      : Disabled
C8000-CBFFF Shadow    : Disabled
CC000-CFFFF Shadow    : Disabled
D0000-D3FFF Shadow    : Disabled
D4000-D7FFF Shadow    : Disabled
D8000-DBFFF Shadow    : Disabled
DC000-DFFFF Shadow    : Disabled
Cyrix 6x86/MII CPUID : Enabled

ESC : Quit           ↑↓↓ : Select Item
F1  : Help           PU/PD/+/- : Modify
F5  : Old Values    (Shift)F2 : Color
F6  : Load BIOS Defaults
F7  : Load Setup Defaults
    
```

### Virus Warning

This category flashes on the screen. During and after the system boots up, any attempt to write to the boot sector or partition table of the hard disk drive will halt the system and the following error message will appear, in the mean time, you can run an anti-virus program to locate the problem.

```

! WARNING !
Disk boot sector is to be modified
Type "Y" to accept write or "N" to abort write
Award Software, Inc.
    
```

Enabled	Activates automatically when the system boots up causing a warning message to appear when anything attempts to access the boot sector or hard disk partition table.
Disabled (Default)	No warning message to appear when anything attempts to access the boot sector or hard disk partition table.

Note: This function is available only for DOS and other OSes that do not trap INT13.

### **CPU Internal Cache/External Cache**

These two categories speed up memory access. However, it depends on CPU/chipset design. The default value is Enable. If your CPU without Internal Cache then this item CPU Internal Cache will not be show.

Enabled (Default)	Enable cache
Disabled	Disable cache

### **Quick Power On Self Test**

This category speeds up Power On Self Test (POST) after you power on the computer. If it is set to Enable, BIOS will shorten or skip some check items during POST.

Enabled	Enable quick POST
Disabled (Default)	Normal POST

### **Boot From LAN First**

This category specifies whether System Boot through the LAN Boot ROM. If not, just disable it.

Enabled	Boot from LAN
Disabled (Default)	Not Boot from LAN

### **Boot Sequence**

This category determines which drive computer searches first for the disk operating system (i.e., DOS). Default value is A,C, SCSI.

A, C, SCSI	Default
C, A, SCSI	
C, CDROM, A	
CDROM, C, A	
D, A, SCSI	
E, A, SCSI	
F, A, SCSI	
SCSI, A, C	
SCSI, C, A	
C only	

LS/ZIP, C	
-----------	--

### **Swap Floppy Drive**

This item allows you to determine whether enable the swap floppy drive or not. The choice: Enabled/Disabled (Default).

### **Boot Up Floppy Seek**

During POST, BIOS will determine if the floppy disk drive installed is 40 or 80 tracks. 360K type is 40 tracks while 760K, 1.2M and 1.44M are all 80 tracks.

Enabled (Default)	BIOS searches for floppy disk drive to determine if it is 40 or 80 tracks. Note that BIOS can not tell from 720K, 1.2M or 1.44M drive type as they are all 80 tracks.
Disabled	BIOS will not search for the type of floppy disk drive by track number. Note that there will not be any warning message if the drive installed is 360K.

### **Boot Up NumLock Status**

The default value is On.

On (Default)	Keypad is number keys
Off	Keypad is arrow keys

### **Boot Up System Speed**

It selects the default system speed - the speed that the system will run at immediately after power up.

High (Default)	Set the speed to high
Low	Set the speed to low

### **Gate A20 Option**

Normal	The A20 signal is controlled by keyboard controller or chipset hardware.
Fast (Default)	Default : Fast. The A20 signal is controlled by Port 92 or chipset specific method.

### **Typematic Rate Setting**

This category determines the typematic rate.

Enabled	Enable typematic rate and typematic delay programming
Disabled (Default)	Disable typematic rate and typematic delay programming. The system BIOS will use default value of this 2 items and the default is controlled by keyboard.

### **Typematic Rate (Chars/Sec)**

6 (Default)	6 characters per second
8	8 characters per second
10	10 characters per second
12	12 characters per second
15	15 characters per second
20	20 characters per second
24	24 characters per second
30	30 characters per second

### **Typematic Delay (Msec)**

When holding a key, the time between the first and second character displayed.

250 (Default)	250 msec
500	500 msec
750	750 msec
1000	1000 msec

### **Security Option**

This category allows you to limit access to the system and Setup, or just to Setup.

System	The system will not boot and access to Setup will be denied if the correct password is not entered at the prompt.
Setup (Default)	The system will boot, but access to Setup will be denied if the correct password is not entered at the prompt.

Note: To disable security, select PASSWORD SETTING at Main Menu and then you will be asked to enter password. Do not type anything and just press <Enter>, it will disable security. Once the security is disabled, the system will boot and you can enter Setup freely.

### **PCI/VGA Palette Snoop**

Enable PCI controller support PCI/VGA palette snoop or not, if enabled, VGA cycle will transfer to ISA bus. If disabled (Default), VGA cycle only transfer to PCI bus.

### **OS Select for DRAM 64MB**

This segment is specifically created for OS/2 when DRAM is larger than 64MB. If your operating system is OS/2 and DRAM used is larger the 64MB, you have to select S 2 otherwise, non-OS2 (Default).

### **Video BIOS Shadow**

It determines whether video BIOS will be copied to RAM, however, it is optional from chipset design. Video Shadow will increase the video speed.

Enabled (Default)	Video shadow is enabled
Disabled	Video shadow is disabled

### **C8000 - CFFFF Shadow/D0000 - DFFFF Shadow**

These categories determine whether optional ROM will be copied to RAM by 16K byte or 32K byte per/unit and the size depends on chipset.

Enabled	Optional shadow is enabled
Disabled (Default)	Optional shadow is disabled

Note:

1. For C8000-DFFFF option-ROM on PCI BIOS , BIOS will automatically enable the shadow RAM. User does not have to select the item.
2. IDE second channel control: Enable : enable secondary IDE port and BIOS will assign IRQ15 for this port.  
Disable: disable secondary IDE port and IRQ15 is available for other device. The item is optional only for PCI BIOS.
3. Some of the sound cards have an onboard CD-ROM controller which uses IDE Secondary Port. In order to avoid PCI IDE conflict, the IDE secondary channel control has to select isable then CD-ROM can work.



## Chipset Features Setup Menu

Since the features in this section are related to the chipset in the CPU board and all are optimized, you are not recommended to change the default settings in the setup table, unless you know very detailed about the chipset features.

ROM PCI/ISA BIOS (E552A-00) CHIPSET FEATURES SETUP AWARD SOFTWARE, INC.	
<pre> Auto Configuration           : Disabled DRAM Leadoff Timing          : 11/7/3 DRAM Read Burst (EDO/FP)    : x222/x333 DRAM Write Burst Timing     : x444 Fast EDO Lead Off           : Disabled Refresh RAS# Assertion      : 4 Clks Fast RAS To CAS Delay       : 3 DRAM Page Idle Timer        : 2 Clks DRAM Enhanced Paging        : Enabled Fast MA to RAS# Delay       : 2 Clks SDRAM(CAS Lat/RAS-to-CAS)  : 2/2 SDRAM Speculative Read      : Disabled System BIOS Cacheable      : Disabled 8 Bit I/O Recovery Time     : NA 16 Bit I/O Recovery Time    : NA Memory Hole At 15M-16M     : Disabled PCI 2.1 Compliance         : Disabled                     </pre>	<pre> ESC : Quit           ↑↓↓+ : Select Item F1  : Help           PU/PD/+/- : Modify F5  : Old Values    (Shift)F2 : Color F6  : Load BIOS Defaults F7  : Load Setup Defaults                     </pre>

### Auto Configuration

Auto Configuration selects predetermined optimal values of chipset parameters. When Disabled, chipset parameters revert to setup information stored in CMOS. Many fields in this screen are not available when Auto Configuration is Enabled.

The Choice: Enabled (Default), Disabled.

Note: When this item is enabled, the pre-defined items will become SHOW-ONLY.

### DRAM Timing

The DRAM timing is controlled by the DRAM Timing Registers. The timings programmed into this register are dependent on the system design. Slower rates may be required in certain system designs to support loose layouts or slower memory.

60ns	DRAM Timing Type.
70ns (Default)	DRAM Timing Type.

**DRAM Read Burst (EDO/FP)**

This sets the timing for burst mode reads from two different DRAM(EDO/FPM). Burst read and write requests are generated by the CPU in four separate parts. The first part provides the location within the DRAM where the read or write is to take place while the remaining three parts provide the actual data. The lower the timing numbers, the faster the system will address memory.

x222/x333	Read DRAM (EDO/FPM) timings are 2-2-2/3-3-3
x333/x444 (Default)	Read DRAM (EDO/FPM) timings are 3-3-3/4-4-4
x444/x444	Read DRAM (EDO/FPM) timings are 4-4-4/4-4-4

**DRAM Write Burst Timing**

This sets the timing for burst mode writes from DRAM. Burst read and write requests are generated by the CPU in four separate parts. The first part provides the location within the DRAM where the read or write is to take place while the remaining three parts provide the actual data. The lower the timing numbers, the faster the system will address memory.

x222	Write DRAM timings are 2-2-2-2
x333 (Default)	Write DRAM timings are 3-3-3-3
x444	Write DRAM timings are 4-4-4-4

**Fast EDO Lead Off**

The item allows you to select the Fast EDO Lead Off or not to enhance the performance. The Choice: Enabled, Disabled (Default).

**Refresh RAS# Assertion**

This item allows you to select the type of DRAM refresh clock delay.

4Clks	The timing type.
5Clks (Default)	The timing type.

**Fast RAS To CAS Delay**

This field lets you insert a timing delay to get a faster performance between the Row Address Strobe (RAS) to Column Address Strobe (CAS) strobe signals, used when DRAM is written to, read from, or refreshed.

2	The timing delay
3 (Default)	The timing delay.

**DRAM Enhanced Paging**

---

This item allows you to determine whether to keep the page open until a page/row miss or use additional information to keep the DRAM page open when host may be right back  
 The Choice: Enabled (Default), Disabled.

### **Fast MA To RAS# Delay**

This item allows you to select the DRAM Row Miss timing. Note: the timing adjustments are independent of DLT timing adjustment.

1	One clocks. (MA setup to RAS# assertion)
2	Two clocks (Default).

### **SDRAM (CAS Lat/RAS-to-CAS)**

This item allows you to select the CAS# latency for all SDRAM cycles and RAS# to CAS# delay.

2/2	The timing type.
3/3 (Default)	The timing type.

### **SDRAM Speculative Read**

This item is capable of allowing a DRAM read request to be generated slightly before the address has been fully decoded. This can reduce all read latencies.

More simply, the CPU will issue a read request and included with this request is the place (address) in memory where the desired data is to be found. This request is received by the DRAM controller. When it is enabled, the controller will issue the read command slightly before it has finished determining the address.

The Choice: Enabled, Disabled (Default).

### **System BIOS Cacheable**

Select Enabled allows caching of the system BIOS ROM at F000h-FFFFh, resulting in better system performance. However, if any program writes to this memory area, a system error may result.

Enabled	BIOS access cached
Disabled (Default)	BIOS access not cached

### **Video BIOS Cacheable**

Select Enabled allows caching of the video BIOS ROM at C0000h-F7FFFh, resulting in better video performance. However, if any program writes to this memory area, a system error may result.

Enabled	Video BIOS access cached
Disabled (Default)	Video BIOS access not cached

### **8 Bit I/O Recovery Time**

The recovery time is the length of time, measured in CPU clocks, which the system will delay after the completion of an input/output request. This delay takes place because the CPU is operating so much faster than the input/output bus that the CPU must be delayed to allow for the completion of the I/O. This item allows you to determine the recovery time allowed for 8 bit I/O. Choices are from NA, 1 (Default) to 8 CPU clocks.

### **16 Bit I/O Recovery Time**

This item allows you to determine the recovery time allowed for 16 bit I/O. Choices are NA, 1,2 (Default), 3, 4 CPU clocks.

### **Memory Hole At 15M-16M.**

In order to improve performance, certain space in memory can be reserved for ISA cards.. This memory must be mapped into the memory space below 16 MB.

Enabled	Memory hole supported.
Disabled (Default)	Memory hole not supported

## Power Management Setup

The Power management setup will appear on your screen like this:

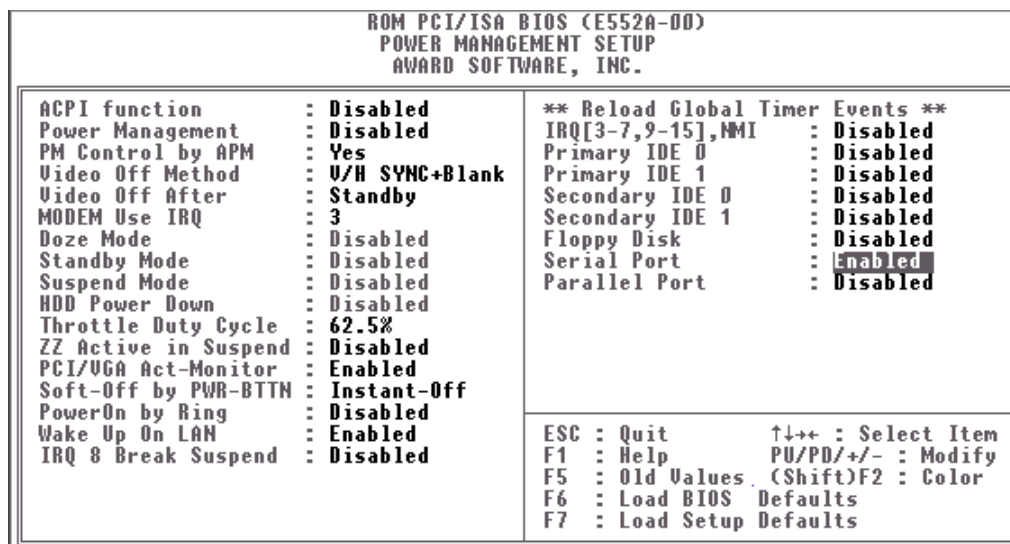

### Power Management

This category allows you to select the type (or degree) of power saving and is directly related to the following modes:

1. Doze Mode
2. Standby Mode
3. Suspend Mode
4. HDD Power Down

There are four selections for Power Management, three of which have fixed mode settings.

Disabled	No power management. Disable all four modes
Min. Power Saving	Minimum power management. Doze Mode = 1 hr. Standby Mode = 1 hr., Suspend Mode = 1 hr., and HDD Power Down = 15 min.
Max. Power Saving (Default)	Maximum power management -- <b>ONLY AVAILABLE FOR SL CPU</b> . Doze Mode = 1 min., Standby Mode = 1 min., Suspend Mode = 1 min., and HDD Power Down = 1 min.
User Define	Allows you to set each mode individually. When not disabled, each of the ranges are from 1 min. to 1 hr. except for HDD Power Down which ranges from 1 min. to 15 min. and disable.

### **PM Control by APM**

When enabled, an Advanced Power Management device will be activated to enhance the Max. Power Saving mode and stop the CPU internal clock. If the Max. Power Saving is not enabled, this will be preset to *No*.

### **Video Off Method**

This determines the manner in which the monitor is blanked.

V/H SYNC+Blank (Default)	This selection will cause the system to turn off the vertical and horizontal synchronization ports and write blanks to the video buffer.
Blank Screen	This option only writes blanks to the video buffer.
DPMS	Initial display power management signaling.

### **Video Off After**

When enabled, this feature allows the VGA adapter to operate in a power saving mode.

N/A	Monitor will remain on during power saving modes.
Suspend	Monitor blanked when the systems enters the Suspend mode.
Standby	Monitor blanked when the system enters Standby mode.
Doze	Monitor blanked when the system enters any power saving mode.

### **MODEM Use IRQ**

Name the interrupt request (IRQ) line assigned to the modem (if any) on your system. Activity of the selected IRQ always awakens the system.

The choices: NA, 3 (Default), 4, 5, 7, 9, 10, 11

PM Timers

The following four modes are Green PC power saving functions which are only user configurable when *User Defined* Power Management has been selected. See above for available selections.

### **Doze Mode**

When enabled and after the set time of system inactivity, the CPU clock will run at slower speed while all other devices still operate at full speed.

Standby Mode

When enabled and after the set time of system inactivity, the fixed disk drive and the video would be shut off while all other devices still operate at full speed.

### **Standby Mode**

1. Disable	System will never enter STANDBY mode
2. 1 Min 2 Min 4 Min 6 Min 8 Min 10 Min 20 Min 30 Min 40 Min 1 Hr	Defines the continuous idle time before the system entering STANDBY mode.  If any item defined in (J) is enabled & active, STANDBY timer will be reloaded

### **Suspend Mode**

When enabled and after the set time of system inactivity, all devices except the CPU will be shut off.

### **HDD Power Down**

When enabled and after the set time of system inactivity, the hard disk drive will be powered down while all other devices remain active.

### **Throttle Duty Cycle**

When the system enters Doze mode, the CPU clock runs only part of the time. You may select the percent of time that the clock runs.  
The Choice: 12.5%, 25.0%, 37.5%, 50.0%, 62.5% (Default), 75.0%

### **PCI/VGA Active Monitor**

When Enabled, any video activity restarts the global timer for Standby mode.  
The Choice: Enabled (Default), Disabled.

### **PowerOn by Ring**

An input signal on the serial Ring Indicator (RI) line (in other words, an incoming call on the modem) awakens the system from a soft off state..  
The Choice: Enabled (Default), Disabled.

### **IRQ 8 Break Suspend**

You can Enable or Disable monitoring of IRQ8 so it does not awaken the system from Suspend mode. The Choice: Enabled, Disabled (Default).

### **Reload Global Timer Events**

When Enabled, an event occurring on each device listed below restarts the global time for Standby mode.

IRQ[3 -7, 9-15], NMI	Enabled (Default), Disabled
Primary IDE 0	Enabled, Disabled (Default)
Primary IDE 1	Enabled, Disabled (Default)
Secondary IDE 0	Enabled, Disabled (Default)
Secondary IDE 1	Enabled, Disabled (Default)
Floppy Disk	Enabled, Disabled (Default)
Serial Port	Enabled (Default), Disabled
Parallel Port	Enabled, Disabled (Default)

## PnP/PCI Configuration

This section describes configuring the PCI bus system. PCI, or Peripheral Component Interconnect, is a system which allows I/O devices to operate at speeds nearing the speed the CPU itself uses when communicating with its own special components. This section covers some very technical items and it is strongly recommended that only experienced users should make any changes to the default settings.

ROM PCI/ISA BIOS (E552A-00) PNP/PCI CONFIGURATION AWARD SOFTWARE, INC.	
PNP OS Installed : <b>Yes</b> Resources Controlled By : <b>Manual</b> Reset Configuration Data : <b>Disabled</b>	Slot 1 Use IRQ No. : <b>Auto</b> Slot 2 Use IRQ No. : <b>Auto</b> Slot 3 Use IRQ No. : <b>Auto</b> Slot 4 Use IRQ No. : <b>Auto</b> PCI IDE IRQ Map To : <b>ISA</b>
IRQ-3 assigned to : <b>PCI/ISA PnP</b> IRQ-4 assigned to : <b>PCI/ISA PnP</b> IRQ-5 assigned to : <b>PCI/ISA PnP</b> IRQ-7 assigned to : <b>PCI/ISA PnP</b> IRQ-9 assigned to : <b>PCI/ISA PnP</b> IRQ-10 assigned to : <b>PCI/ISA PnP</b> IRQ-11 assigned to : <b>PCI/ISA PnP</b> IRQ-12 assigned to : <b>PCI/ISA PnP</b> IRQ-14 assigned to : <b>PCI/ISA PnP</b> IRQ-15 assigned to : <b>PCI/ISA PnP</b> DMA-0 assigned to : <b>PCI/ISA PnP</b> DMA-1 assigned to : <b>PCI/ISA PnP</b> DMA-3 assigned to : <b>PCI/ISA PnP</b> DMA-5 assigned to : <b>PCI/ISA PnP</b> DMA-6 assigned to : <b>PCI/ISA PnP</b> DMA-7 assigned to : <b>PCI/ISA PnP</b>	Assign IRQ For USB : <b>Disabled</b> Used MEM base addr : <b>N/A</b>
	ESC : Quit            ↑↓++ : Select Item F1 : Help            PU/PD/+/- : Modify F5 : Old Values      (Shift)F2 : Color F6 : Load BIOS Defaults F7 : Load Setup Defaults

### PNP OS Installed

Select Yes if the system operating environment is Plug-and-Play aware (e.g. Windows 95). The Choice: Yes and No (Default).

### Resource Controlled by

The Award Plug and Play BIOS can automatically configure all the boot and Plug and Play-compatible devices. If you select Auto, all the interrupt request (IRQ) and DMA assignment fields disappear, as the BIOS automatically assigns them.

The choice: *Auto* (Default) and Manual.

### Reset Configuration Data

Normally, you leave this field Disabled. Select Enabled to reset Extended System Configuration Data (ESCD) when you exit Setup if you have installed a new add-on and the system reconfiguration has caused such a serious conflict that the operating system cannot boot. The choice: *Enabled* and *Disabled* (Default).

**Assing IRQ For USB**

Assing IRQ for USB : Enabled (Default)

Not assign IRQ for USB : Disabled

## Integrated Peripherals

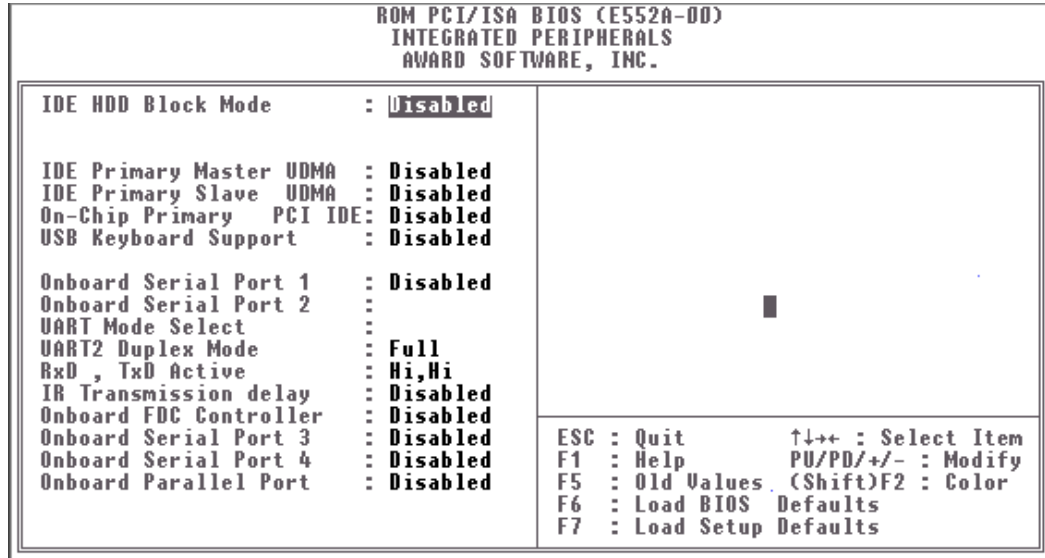

### IDE HDD Block Mode

This allows your hard disk controller to use the fast block mode to transfer data to and from your hard disk drive (HDD).

Enabled	IDE controller uses block mode.
Disabled (Default)	IDE controller uses standard mode.

### IDE Primary/Secondary Master/Slave PIO

The four IDE PIO (Programmed Input/Output) fields let you set a PIO mode (0-4) for each of the four IDE devices that the onboard IDE interface supports. Modes 0 through 4 provide successively increased performance. In Auto mode, the system automatically determines the best mode for each device.

### IDE Primary/Secondary Master/Slave UDMA

Ultra DMA/33 implementation is possible only if your IDE hard drive supports it and the operating environment includes a DMA driver (Windows 95 OSR2 or a third-party IDE bus master driver). If your hard drive and your system software both support Ultra DMA/33, select Auto to enable BIOS support. The Choice: Auto (Default), Disabled

### **On-Chip Primary/Secondary PCI IDE**

The integrated peripheral controller contains an IDE interface with support for two IDE channels. Select Enabled (Default) to activate each channel separately.

### **Onboard PCI SCSI Chip**

This item allows you to determine whether onboard PCI SCSI chip is enabled (Default) or not.

### **USB Keyboard Support**

Select Enabled if your system contains a Universal Serial Bus (USB) controller and you have a USB keyboard. The Choice: Enabled, Disabled (Default).

### **Onboard Serial Port 1/Port 2/Port 3/Port 4**

This item allows you to determine access onboard serial port 1/port 2 controller with which I/O address. The Choice: 3F8/IRQ4, 2F8/IRQ3, 3E8/IRQ4, 2F8/IRQ3, Disabled, Auto (Default).

### **UART Mode**

This item allows you to determine which Infra Red (IR) function of onboard I/O chip. The Choice: Normal (Default), ASK-IR, IrDA.

### **Onboard FDC Controller**

Select Enabled if your system has a floppy disk controller (FDC) installed on the system board and you wish to use it. If you install and-in FDC or the system has no floppy drive, select Disabled in this field. Choices: Enabled (Default), Disabled.

### **Onboard Parallel Port**

Select a logical LPT port name and matching address for the physical parallel (printer) port. The choice: 378H/IRQ7 (Default), 278H/IRQ5, 3BCH/IRQ7, Disabled.

## *Supervisor/User Password Setting*

You can set either supervisor or user password, or both of them. The differences between are:

supervisor password : can enter and change the options of the setup menus.

user password : just can enter but do not have the right to change the options of the setup menus.

When you select this function, the following message will appear at the center of the screen to assist you in creating a password.

### ENTER PASSWORD:

Type the password, up to eight characters in length, and press <Enter>. The password typed now will clear any previously entered password from CMOS memory. You will be asked to confirm the password. Type the password again and press <Enter>. You may also press <Esc> to abort the selection and not enter a password.

To disable a password, just press <Enter> when you are prompted to enter the password. A message will confirm the password will be disabled. Once the password is disabled, the system will boot and you can enter Setup freely.

### PASSWORD DISABLED.

When a password has been enabled, you will be prompted to enter it every time you try to enter Setup. This prevents an unauthorized person from changing any part of your system configuration.

Additionally, when a password is enabled, you can also require the BIOS to request a password every time your system is rebooted. This would prevent unauthorized use of your computer.

You determine when the password is required within the BIOS Features Setup Menu and its Security option (see Section 4). If the Security option is set to system the password will be required both at boot and at entry to Setup. If set to setup prompting only occurs when trying to enter Setup.

## IDE HDD Auto Detection

The Enhance IDE features was included in all Award BIOS. Below is a brief description of this feature.

### 1. Setup Changes

<I> Auto-detection

BIOS setup will display all possible modes that supported by the HDD including NORMAL, LBA & LARGE.

If HDD does not support LBA modes, no LBA option will be shown.

Users can select a mode which is appropriate for them.

ROM/PCI/ISA BIOS (2XXXXXXX)  
CMOS SETUP UTILITY  
AWARD SOFTWARE, INC.

HARD DISKS	TYPE	SIZE	CYLS	HEAD	PRECOMP	LANDZ	SECTOR	MODE
Primary Master :								
Select Primary Master Option (N = Skip) : N								
	OPTION	SIZE	CYLS	HEADS	PRECOMP	LANDZ	SECTORS	MODE
	1(Y)	516	1120	1	65535	1119	59	NORMAL
	2	516	524	32	0	1119	63	LBA
	3	516	560	32	65535	1119	59	LARGE

### <II> Standard CMOS Setup

HARD DISK	TYPE	Cyls	Heads	Precomp	Landzon e	Sector	Mode
Primary Master:	User (516MB)	1120	16	65535	1119	59	Normal
Primary Slave:	None (203MB)	684	16	65535	685	38	-----
Secondary Master:	None	0	0	0	0	0	0
Secondary Slave	None	0	0	0	0	0	0

When HDD type is in user type, the ODE option will be opened for user to select their own HDD mode.

(2) HDD Modes

The Award BIOS supports 3 HDD modes : NORMAL, LBA & LARGE

NORMAL mode

Generic access mode in which neither the BIOS nor the IDE controller will make any transformations during accessing.

The maximum number of cylinders, head & sectors for NORMAL mode are 1024, 16 & 63.

$$\begin{array}{r} \text{no. Cylinder} \qquad \qquad \qquad (1024) \\ \times \text{ no. Head} \qquad \qquad \qquad ( 16) \\ \times \text{ no. Sector} \qquad \qquad \qquad ( 63) \\ \hline \times \text{ no. per sector} \qquad \qquad \qquad ( 512) \\ \hline \qquad \qquad \qquad \qquad \qquad \qquad 528 \text{ Megabytes} \end{array}$$

If user set his HDD to NORMAL mode, the maximum accessible HDD size will be 528 Megabytes even though its physical size may be greater than that!

LBA (Logical Block Addressing) mode

A new HDD accessing method to overcome the 528 Megabyte bottleneck. The number of cylinders, heads & sectors shown in setup may not be the number physically contained in the HDD.

During HDD accessing, the IDE controller will transform the logical address described by sector, head & cylinder number into its own physical address inside the HDD.

The maximum HDD size supported by LBA mode is 8.4 Gigabytes which is obtained by the following formula:

$$\begin{array}{r} \text{no. Cylinder} \qquad \qquad \qquad ( 1024) \\ \times \text{ no. Head} \qquad \qquad \qquad ( 255) \\ \times \text{ no. Sector} \qquad \qquad \qquad ( 63) \\ \hline \times \text{ bytes per sector} \qquad \qquad \qquad ( 512) \\ \hline \qquad \qquad \qquad \qquad \qquad \qquad 8.4 \text{ Gigabytes} \end{array}$$

LARGE mode

Extended HDD access mode supported by Award Software.

Some IDE HDDs contain more than 1024 cylinder without LBA support (in some cases, user do not want LBA). The Award BIOS provides another alternative to support these kinds of HDD!

Example of LARGE mode:

CYLS.	HEAD	SECTOR	MODE
1120	16	59	NORMAL
560	32	59	LARGE

BIOS tricks DOS (or other OS) that the number of cylinders is less than 1024 by dividing it by 2. At the same time, the number of heads is multiplied by 2. A reverse ransformation process will be made inside INT13h in order to access the right HDD address!

Maximum HDD size:

no. Cylinder	( 1024)
x no. Head	( 32)
x no. Sector	( 63)
x bytes per sector	( 512)
	<hr/>
	1 Gigabytes

(3) Remarks

To support LBA or LARGE mode of HDDs, there must be some softwares involved. All these softwares are located in the Award HDD Service Routine(INT 13h). It may be failed to access a HDD with LBA (LARGE) mode selected if you are running under a Operating System which replaces the whole INT 13h.

## *Hard Disk Low Level Format Utility*

This Award Low-Level-Format Utility is designed as a tool to save your time formatting your hard disk. The Utility automatically looks for the necessary information of the drive you selected. The Utility also searches for bad tracks and lists them for your reference.

Shown below is the Main Menu after you enter into the Award Low-Level-Format Utility.

Hard Disk Low Level Format Utility								
SELECT DRIVE BAD TRACK LIST PREFORMAT		NO. CYLS HEAD						
Current select drive is: C								
DRIVE: C CYLINDER: 0 HEAD : 0								
		Size	Cyls	Head	Precom p	Landz	Sector	Mode
Primary Master	:	0	0	0	0	0	0	AUTO
Primary Slave	:	0	0	0	65535	65535	0	AUTO
Secondary Master	:	0	0	0	0	0	0	AUTO
Secondary Slave	:	0	0	0	0	65280	0	AUTO
Up/Down- Select item      ENTER-Accept      ESC-Exit/Abort Copyright (C) Award Software, Inc. 1992-98 All Rights Reserved								

### Control Keys

Use the Up and Down arrow keys to move around the selections displayed on the upper screen. Press [Enter] to accept the selection. Press Esc to abort the selection or exit the Utility.

### SELECT DRIVE

Select from installed hard disk drive C or D. List at the bottom of the screen is the drive automatically detected by the utility.

## **BAD TRACK LIST**

### Auto scan bad track

The utility will automatically scan bad tracks and list the bad tracks in the window at the right side of the screen.

### Add bad track

Directly type in the information of the known bad tracks in the window at the right side of the screen.

### Modify bad track

Modify the information of the added bad tracks in the window at the right side of the screen.

### Delete bad track

Delete the added bad tracks in the window at the right side of the screen.

### Clear bad track table

Clear the whole bad track list in the window at the right side of the screen.

## **PREFORMAT**

### Interleave

Select the interleave number of the hard disk drive you wish to perform low level format. You may select from 1 to 8. Check the documentation that came with the drive for the correct interleave number, or select 0 for utility automatic detection.

### Auto scan bad track

This allows the utility to scan first then format by each track.

### Start

Press <Y> to start low level format.

## *Power-On Boot*

After you have made all the changes to CMOS values and the system cannot boot with the CMOS values selected in Setup, restart the system by turning it OFF then ON or Pressing the "RESET" button on the system case. You may also restart by simultaneously press <Ctrl>, <Alt>, and <Delete> keys. Upon restart the system, immediately press <Insert> to load BIOS default CMOS value for boot up.

## *BIOS Reference - POST Message*

During the Power On Self Test (POST), if the BIOS detects an error requiring you to do something to fix, it will either sound a beep code or display a message.

If a message is displayed, it will be accompanied by:

PRESS F1 TO CONTINUE, CTRL-ALT-ESC OR DEL TO ENTER SETUP

### **POST Beep**

Currently there is only one beep code in BIOS. This code indicates that a video error has occurred and the BIOS cannot initialize the video screen to display any additional information. This beep code consists of a single long beep followed by two short beeps.

### **Error Messages**

One or more of the following messages may be displayed if the BIOS detects an error during the POST. This list includes messages for both the ISA and the EISA BIOS.

#### **CMOS BATTERY HAS FAILED**

CMOS battery is no longer functional. It should be replaced.

#### **CMOS CHECKSUM ERROR**

Checksum of CMOS is incorrect. This can indicate that CMOS has become corrupt. This error may have been caused by a weak battery. Check the battery and replace if necessary.

#### **DISK BOOT FAILURE, INSERT SYSTEM DISK AND PRESS ENTER**

No boot device was found. This could mean that either a boot drive was not detected or the drive does not contain proper system boot files. Insert a system disk into Drive A: and press <Enter>. If you assumed the system would boot from the hard drive, make sure the controller is inserted correctly and all cables are

properly attached. Also be sure the disk is formatted as a boot device. Then reboot the system.

#### **DISKETTE DRIVES OR TYPES MISMATCH ERROR - RUN SETUP**

Type of diskette drive installed in the system is different from the CMOS definition. Run Setup to reconfigure the drive type correctly.

#### **DISPLAY SWITCH IS SET INCORRECTLY**

Display switch on the motherboard can be set to either monochrome or color. This indicates the switch is set to a different setting than indicated in Setup. Determine which setting is correct, and then either turn off the system and change the jumper, or enter Setup and change the VIDEO selection.

#### **DISPLAY TYPE HAS CHANGED SINCE LAST BOOT**

Since last powering off the system, the display adapter has been changed. You must configure the system for the new display type.

#### **EISA Configuration Checksum Error PLEASE RUN EISA CONFIGURATION UTILITY**

The EISA non-volatile RAM checksum is incorrect or cannot correctly read the EISA slot. This can indicate either the EISA non-volatile memory has become corrupt or the slot has been configured incorrectly. Also be sure the card is installed firmly in the slot.

#### **EISA Configuration Is Not Complete PLEASE RUN EISA CONFIGURATION UTILITY**

The slot configuration information stored in the EISA non-volatile memory is incomplete.

Note: When either of these errors appear, the system will boot in ISA mode, which allows you to run the EISA Configuration Utility.
---

### **ERROR ENCOUNTERED INITIALIZING HARD DRIVE**

Hard drive cannot be initialized. Be sure the adapter is installed correctly and all cables are correctly and firmly attached. Also be sure the correct hard drive type is selected in Setup.

### **ERROR INITIALIZING HARD DISK CONTROLLER**

Cannot initialize controller. Make sure the cord is correctly and firmly installed in the bus. Be sure the correct hard drive type is selected in Setup. Also check to see if any jumper needs to be set correctly on the hard drive.

### **FLOPPY DISK CNTRLR ERROR OR NO CNTRLR PRESENT**

Cannot find or initialize the floppy drive controller. make sure the controller is installed correctly and firmly. If there are no floppy drives installed, be sure the Diskette Drive selection in Setup is set to NONE.

### **Invalid EISA Configuration**

#### **PLEASE RUN EISA CONFIGURATION UTILITY**

The non-volatile memory containing EISA configuration information was programmed incorrectly or has become corrupt. Re-run EISA configuration utility to correctly program the memory.

<p>NOTE: When this error appears, the system will boot in ISA mode, which allows you to run the EISA Configuration Utility.</p>
---

### **KEYBOARD ERROR OR NO KEYBOARD PRESENT**

Cannot initialize the keyboard. Make sure the keyboard is attached correctly and no keys are being pressed during the boot.

If you are purposely configuring the system without a keyboard, set the error halt condition in Setup to HALT ON ALL, BUT KEYBOARD. This will cause the BIOS to ignore the missing keyboard and continue the boot.

### **Memory Address Error at ...**

Indicates a memory address error at a specific location. You can use this location along with the memory map for your system to find and replace the bad memory chips.

### **Memory parity Error at ...**

Indicates a memory parity error at a specific location. You can use this location along with the memory map for your system to find and replace the bad memory chips.

### **MEMORY SIZE HAS CHANGED SINCE LAST BOOT**

Memory has been added or removed since the last boot. In EISA mode use Configuration Utility to reconfigure the memory configuration. In ISA mode enter Setup and enter the new memory size in the memory fields.

### **Memory Verify Error at ...**

Indicates an error verifying a value already written to memory. Use the location along with your system's memory map to locate the bad chip.

### **OFFENDING ADDRESS NOT FOUND**

This message is used in conjunction with the I/O CHANNEL CHECK and RAM PARITY ERROR messages when the segment that has caused the problem cannot be isolated.

### **OFFENDING SEGMENT:**

This message is used in conjunction with the I/O CHANNEL CHECK and RAM PARITY ERROR messages when the segment that has caused the problem has been isolated.

### **PRESS A KEY TO REBOOT**

This will be displayed at the bottom screen when an error occurs that requires you to reboot. Press any key and the system will reboot.

### **PRESS F1 TO DISABLE NMI, F2 TO REBOOT**

When BIOS detects a Non-maskable Interrupt condition during boot, this will allow you to disable the NMI and continue to boot, or you can reboot the system with the NMI enabled.

### **RAM PARITY ERROR - CHECKING FOR SEGMENT ...**

Indicates a parity error in Random Access Memory.

**Should Be Empty But EISA Board Found**  
**PLEASE RUN EISA CONFIGURATION UTILITY**

A valid board ID was found in a slot that was configured as having no board ID.

**NOTE:** When this error appears, the system will boot in ISA mode, which allows you to run the EISA Configuration Utility.

**Should Have EISA Board But Not Found**  
**PLEASE RUN EISA CONFIGURATION UTILITY**

The board installed is not responding to the ID request, or no board ID has been found in the indicated slot.

**NOTE:** When this error appears, the system will boot in ISA mode, which allows you to run the EISA Configuration Utility.

**Slot Not Empty**

Indicates that a slot designated as empty by the EISA Configuration Utility actually contains a board.

**NOTE:** When this error appears, the system will boot in ISA mode, which allows you to run the EISA Configuration Utility.

**SYSTEM HALTED, (CTRL-ALT-DEL) TO REBOOT ...**

Indicates the present boot attempt has been aborted and the system must be rebooted. Press and hold down the CTRL and ALT keys and press DEL.

**Wrong Board In Slot**  
**PLEASE RUN EISA CONFIGURATION UTILITY**

The board ID does not match the ID stored in the EISA non-volatile memory.

**NOTE:** When this error appears, the system will boot in ISA mode, which allows you to run the EISA configuration utility.

*BIOS Reference - POST Codes*

**Note:** EISA POST codes are typically output to port address 300h.  
ISA POST codes are output to port address 80h.

POST (hex)	Description
C0	1. Turn off OEM specific cache, shadow... 2. Initialize all the standard devices with default values standard devices includes: -DMA controller (8237) -Programmable Interrupt Controller (8259) -Programmable Interval Timer (8254) -RTC chip
C1	Auto-detection of onboard DRAM & Cache
C3	1. Test system BIOS checksum 2. Test the first 256K DRAM 3. Expand the compressed codes into temporary DRAM area including the compressed System BIOS & Option ROMs
C5	Copy the BIOS from ROM into E0000-FFFFFF shadow RAM so that POST will go faster
01-02	Reserved
03	Initialize EISA registers (EISA BIOS only)
04	Reserved
05	1. Keyboard Controller Self-Test 2. Enable Keyboard Interface
06	Reserved
07	Verifies CMOS basic R/W functionality
BE	Program defaults values into chipset according to the MODBINable Chipset Default Table
09	1. Program the configuration register of Cyrix CPU according to the MODBINable Cyrix Register Table 2. OEM specific cache initialization (if needed)
0A	1. Initialize the first 32 interrupt vectors with corresponding Interrupt handlers Initialize INT no from 33-120 with Dummy(Suprious) Interrupt Handler 2. Issue CPUID instruction to identify CPU type 3. Early Power Management initialization (OEM specific)

✿ **This POST code is for boot block**

<b>POST (hex)</b>	<b>Description</b>
C0	1. Turn off OEM specific cache, shadow... 2. Initialize all the standard devices with default values standard devices includes: -DMA controller (8237) -Programmable Interrupt Controller (8259) -Programmable Interval Timer (8254) -RTC chip
C1	Auto-detection of onboard DRAM & Cache
C3	Checking checksum of compressed code
C5	Copy the BIOS from ROM into E0000-FFFFFF shadow RAM so that POST will go faster
01	Clear base memory 0~640K
0C	Initial interrupt vector 00-1FH
0D	Initial ISA VGA
41H	Enable FDD and detect media type
FFH	Boot from FDD

✿ **This page is for Non-Compressed Version only**

01-02	Reserved
C0	Turn off OEM specific cache, shadow...
03	<ol style="list-style-type: none"> <li>1. Initialize EISA registers (EISA BIOS only)</li> <li>2. Initialize all the standard devices with default values</li> </ol> Standard devices includes: <ul style="list-style-type: none"> <li>-DMA controller (8237)</li> <li>-Programmable Interrupt Controller (8259)</li> <li>-Programmable Interval Timer (8254)</li> <li>-RTC chip</li> </ul>
04	Reserved
05	<ol style="list-style-type: none"> <li>1. Keyboard Controller Self-Test</li> <li>2. Enable Keyboard Interface</li> </ol>
06	Reserved
07	Verifies CMOS basic R/W functionality
BE	Program defaults values into chipset according to the MODBINable Chipset Default Table
C1	Auto-detection of onboard DRAM & Cache
C5	Copy the BIOS from ROM into E0000-FFFFFF shadow RAM so that POST will go faster
08	Test the first 256K DRAM
09	<ol style="list-style-type: none"> <li>1. Program the configuration register of Cyrix CPU according to the MODBINable Cyrix Register Table</li> <li>2. OEM specific cache initialization (if needed)</li> </ol>
0A	<ol style="list-style-type: none"> <li>1. Initialize the first 32 interrupt vectors with corresponding Interrupt handlers Initialize INT no from 33-120 with Dummy(Suprious) Interrupt Handler</li> <li>2. Issue CPUID instruction to identify CPU type</li> <li>3. Early Power Management initialization (OEM specific)</li> </ol>

- ✿ The following POST Codes are for all of Compress Version & Non-Compress Version

POST (hex)	Description
0B	<ol style="list-style-type: none"> <li>1. Verify the RTC time is valid or not</li> <li>2. Detect bad battery</li> <li>3. Read CMOS data into BIOS stack area</li> <li>4. PnP initializations including (PnP BIOS only)                             <ul style="list-style-type: none"> <li>-Assign CSN to PnP ISA card</li> <li>-Create resource map from ESCD</li> </ul> </li> <li>5. Assign IO &amp; Memory for PCI devices (PCI BIOS only)</li> </ol>
0C	Initialization of the BIOS Data Area (40 : 00 – 40:FF)
0D	<ol style="list-style-type: none"> <li>1. Program some of the Chipset value according to Setup. (Early Setup Value Program)</li> <li>2. Measure CPU speed for display &amp; decide the system clock speed</li> <li>3. Video initialization including Monochrome, CGA, EGA/VGA. If no display device found, the speaker will beep which consists of one single long beep followed by two short beeps.</li> </ol>
0E	<ol style="list-style-type: none"> <li>1. Initialize the APIC (Multi-Processor BIOS only)</li> <li>2. Test video RAM (If Monochrome display device found)</li> <li>3. Show messages including:                             <ul style="list-style-type: none"> <li>-Award Logo, Copyright string, BIOS Date code &amp; Part No.</li> <li>-OEM specific sign on messages</li> <li>-Energy Star Logo (Green BIOS ONLY)</li> <li>-CPU brand, type &amp; speed</li> <li>-Test system BIOS checksum(Non-Compress Version only)</li> </ul> </li> </ol>
0F	DMA channel 0 test
10	DMA channel 1 test
11	DMA page registers test
12-13	Reserved
14	Test 8254 Timer 0 Counter 2.
15	Test 8259 interrupt mask bits for channel 1
16	Test 8259 interrupt mask bits for channel 2
17	Reserved
19	Test 8259 functionality
1A-1D	Reserved

1E	If EISA NVM checksum is good, execute EISA initialization (EISA BIOS only)
1F-29	Reserved
30	Detect Base Memory & Extended Memory Size
31	1. Test Base Memory from 256K to 640K 2. Test Extended Memory from 1M to the top of memory
32	1. Display the Award Plug & Play BIOS Extension message (PnP BIOS only) 2. Program all onboard super I/O chips (if any) including COM ports, LPT ports, FDD port... according to setup value
POST(hex)	Description
33-3B	Reserved
3C	Set flag to allow users to enter CMOS Setup Utility
3D	1. Initialize Keyboard 2. Install PS2 mouse
3E	Try to turn on Level 2 cache Note: Some chipset may need to turn on the L2 cache in this stage. But usually, the cache is turn on later in POST 61h
BF	1. Program the rest of the Chipset value according to Setup. (Later Setup Value Program) 2. If auto-configuration is enabled, programmed the chipset with pre-defined values in the MODBINable Auto-Table
41	Initialize floppy disk drive controller
42	Initialize Hard drive controller
43	If it is a PnP BIOS, initialize serial & parallel ports
44	Reserved
45	Initialize math coprocessor.
46-4D	Reserved
4E	If there is any error detected (such as video, kb...), show all the error messages on the screen & wait for user to press <F1> key
4F	1. If password is needed, ask for password 2. Clear the Energy Star Logo (Green BIOS only)
50	Write all CMOS values currently in the BIOS stack area back into the CMOS
51	Reserved

52	<ol style="list-style-type: none"><li>1. Initialize all ISA ROMs</li><li>2. Later PCI initializations (PCI BIOS only)<ul style="list-style-type: none"><li>-assign IRQ to PCI devices</li><li>-initialize all PCI ROMs</li></ul></li><li>3. PnP Initializations (PnP BIOS only)<ul style="list-style-type: none"><li>-assign IO, Memory, IRQ &amp; DMA to PnP ISA devices</li><li>-initialize all PnP ISA ROMs</li></ul></li><li>4. Program shadows RAM according to Setup settings</li><li>5. Program parity according to Setup setting</li><li>6. Power Management Initialization<ul style="list-style-type: none"><li>-Enable/Disable global PM</li><li>-APM interface initialization</li></ul></li></ol>
53	<ol style="list-style-type: none"><li>1. If it is NOT a PnP BIOS, initialize serial &amp; parallel ports</li><li>2. Initialize time value in BIOS data area by translate the RTC time value into a timer tick value</li></ol>
60	Setup Virus Protection (Boot Sector Protection) functionality according to Setup setting

## BIOS Default Drive Table

This is a current list of the drive type table contained in Setup.

Type	Size (MB)	Cylinders	Heads	Sectors	Write Precomp	Land Zone	Example Model
1	10	306	4	17	128	305	TEAC SD510, MMI 112, 5412
2	21	615	4	17	300	615	Seagate ST225, ST4026
3	32	615	6	17	300	615	
4	65	940	8	17	512	940	
5	49	940	6	17	512	940	
6	21	615	4	17	65535	615	Seagate ST125, Tandon TM262
7	32	462	8	17	256	511	
8	31	733	5	17	65535	733	Tandon TM 703
9	117	900	15	17	65535	901	
10	21	820	3	17	65535	820	
11	37	855	5	17	65535	855	
12	52	855	7	17	65535	855	
13	21	306	8	17	128	319	Disctron 526, MMI M125
14	44	733	7	17	65535	733	
15		Reserved					
16	21	612	4	17	0	663	Microscience HH725, Syquest 3250, 3425
17	42	977	5	17	300	977	
18	59	977	7	17	65535	977	
19	62	1024	7	17	512	1023	
20	31	733	5	17	300	732	
21	44	733	7	17	300	732	
22	31	733	5	17	300	733	Seagate ST4038
23	10	306	4	17	0	336	
24	42	977	5	17	65535	976	Seagate ST4051

25	80	1024	9	17	65535	1023	Seagate ST4096
26	74	1224	7	17	65535	1223	Maxtor 2085
27	117	1224	11	17	65535	1223	Maxtor 2140, Priam S14
28	159	1224	15	17	65535	1223	Maxtor 2190, Priam S19
Type	Size (MB)	Cylinders	Heads	Sectors	Write Precomp	Land Zone	Example Model
29	71	1024	8	17	65535	1023	Maxtor 1085, Micropolis 1325
30	98	1024	11	17	65535	1023	Maxtor 1105, 1120, 4780
31	87	918	11	17	65535	1023	Maxtor 1170
32	72	925	9	17	65535	926	CDC 9415
33	89	1024	10	17	65535	1023	
34	106	1024	12	17	65535	1023	
35	115	1024	13	17	65535	1023	
36	124	1024	14	17	65535	1023	
37	17	1024	2	17	65535	1023	
38	142	1024	16	17	65535	1023	
39	119	918	15	17	65535	1023	Maxtor 1140, 4380
40	42	820	6	17	65535	820	Seagate ST251
41	44	1024	5	17	65535	1023	Seagate 4053 Miniscribe 3053/6053
42	68	1024	5	26	65535	1023	Miniscribe 3053/6053 RLL
43	42	809	6	17	65535	852	Miniscribe 3650
44	64	809	6	26	65535	852	Miniscribe 3675 RLL
45	104	776	8	33	65535	775	Conner CP3104
Auto							

User							
None							

## Appendix 1

# Watch Dog Timer

### Watch Dog Timer Working Procedure

The Watch Dog Timer (WDT) is the special hardware device. The WDT function is to monitor the computer system whether work normally, otherwise, it will have some measures to fix up the system.

It contains a receivable SQW signal from RTC, and could set time and can clear the counter function. When time is up, WDT can send Reset or NMI signal.

Operator has to write a value into WDT Configuration Register (Write the control value to the Configuration Port), and clear WDT counter (read the Configuration Port).

### Watch Dog Timer character and function

WDT Configuration port	F2	Default at F2
Watch Dog Timer	Disabled Enabled	1. Default at disabled 2. Enabled for user's programming
WDT Time out active for	Reset NMI	Default at Reset
WDT Active Time	1 sec 2 sec 4 sec 8 sec 16 sec 32 sec 64 sec	Default at 64 sec

## Watch Dog Timer Control Register

The Watch Dog Timer Control Register is to control the WDT working mode. You can write the value to WDT Configuration Port.

The following is the Control Register bit definition.

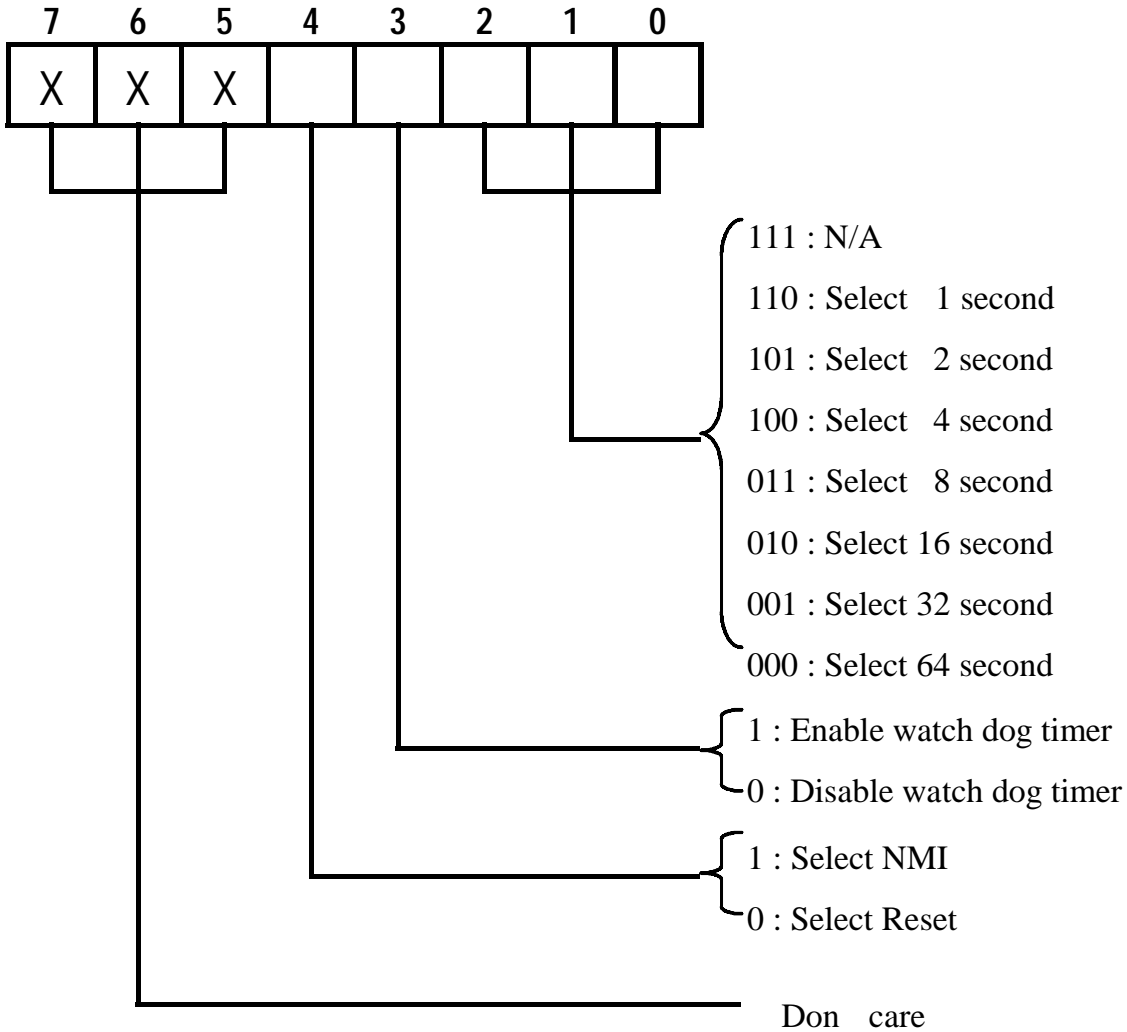

## Watch Dog Timer Programming Procedure

### • Power on or reset the system

The initial value of WDT Control Register (D4~D0) is zero, when power is on or reset the system. The following means the initial value of WDT ( 00000000b ) :

Bit	Value	Mean
4	0	Select Reset
3	0	Disable watch dog timer
2, 1, 0	0 0 0	Select 64 second

### • Initialize the SQW of RTC (set SQW output period=0.5 second)

To initialize the SQW of RTC processor is to set the SQW signal which is output period=0.5 second. It offers the basic frequency of the WDT counter.

The following is an example of **initializing the SQW signal program** in Intel 8086 assembly language.

```

; (Generate SQW = 0.5 Sec.)
Mov dx, 70h
Mov ax, 0Ah
Out dx, al      ; Out port 70h = 0Ah
Mov dx, 71h
Mov ax, 2Fh
Out dx, al      ; Out port 71h = 2Fh
; (enable the SQW output)
Mov dx, 70h
Mov ax, 0Bh
Out dx, al      ; Out port 70h = 0Bh
Mov dx, 71h
Mov ax, 0Ah
Out dx, al      ; Out port 71h = 0Ah

```

**• Clear the WDT**

Repeatedly read WDT Configuration Port and the interval cannot be longer than the preset time, otherwise, the WDT will generate NMI or Reset signal for the system.

The following is an example of **clear the WDT program** in Intel 8086 assembly language.

```
; ( Clear the WDT)
Mov  dx, F2h  ;Setting the WDT configuration port
In   al, dx
```

**Note:** Before running WDT, you must clear the WDT. It means to make sure the initial value is zero before enabling the WDT.

**• WDT Control Register (Write to WDT configuration port)**

You can set the WDT Control Register to control the WDT working mode.

The initial value of the WDT Control Register is as the following.

```
; (Setting the WDT Control Register as AL)
Mov  al, 0h  ; Setting initial value = 0 for the WDT Control Register
```

You must plan the option of following:

1. Select NMI or Reset: decide D4 value in F2.

i.e. Setting D4 = 0, then it select Reset

```
AND  al, 11101111b  ; Select Reset
```

i.e. Setting D4 = 1, then it select NMI

```
OR   al, 00010000b  ; Select NMI
```

2. Select the time-out intervals of WDT (decide the values of D2, D1, D0 in F2 )

Example: D2~D0 = 0, the time-out interval will be 64 sec.

```
AND  al, 11111000b  ; Setting the time-out interval as 64 sec.
```

3. Enable or Disable the WDT ( decide D3 value in F2)

i.e. D3=0, Disable the WDT

```
AND    al, 11110111b    ; Disable the WDT
```

i.e. D3=1, Enable the WDT

```
OR     al, 00001000b    ; Enable the WDT
```

After finishing the above setting, you must be output for the Control Register value to the WDT Configuration Port. Then WDT will start according to the above setting.

```
MOV    dx, F2h          ; Setting WDT Configuration Port  
OUT    dx, al           ; Output the Control Register Value
```

- You should build in a mechanism in the program to continue to read the WDT Configuration Port for clearing WDT before the time out.