

WAFER-5823

Low Power GX1 MMX with SVGA/LCD, Ethernet, SBC. Ver1.2

Manual Revision 1.2
June 6, 2002

Copyright Notice

©2001 Copyright by ICP Electronics Inc. All rights reserved.

The information in this document is subject to change without prior notice in order to improve reliability, design and function and does not represent a commitment on the part of the manufacturer.

In no event will the manufacturer be liable for direct, indirect, special, incidental, or consequential damages arising out of the use or inability to use the product or documentation, even if advised of the possibility of such damages.

This document contains proprietary information protected by copyright. All rights are reserved. No part of this manual may be reproduced by any mechanical, electronic, or other means in any form without prior written permission of the manufacturer.

Trademarks

WAFER-5823 is a registered trademark of ICP Electronics Inc. IBM PC is a registered trademark of International Business Machines Corporation. Intel is a registered trademark of Intel Corporation. Other product names mentioned herein are used for identification purposes only and may be trademarks and/or registered trademarks of their respective companies

Contents

1 Introduction	5
1.1 Specifications	5
1.2 What You Have	7
2 Installation	8
2.1 WAFER-5823 Block Diagram & Board Layout.....	8
2.2 Unpacking Precautions	11
2.3 System Memory DRAM	11
2.4 Watch-Dog Timer Setting.....	11
2.5 Clear CMOS Setup.....	12
2.6 LCD Vcc Voltage selector	12
2.7 Compact Flash setting.....	13
3 Connection	14
3.1 Floppy Disk Drive Connector (CN2)	14
3.2 PCI E-IDE Disk Drive Connector (CN10)	15
3.3 Compact Flash Connector (CN11)	16
3.4 Parallel Port (CN7)	17
3.5 Serial Ports (CN5,CN6)	17
3.6 Keyboard & PS/2 Mouse Connector (CN1)	18
3.7 USB Port Connector (CN12).....	19
3.8 IrDA Infrared Interface Port (CN8).....	19
3.9 VGA Connector (CN16).....	19
3.10 LAN RJ45 Connector (CN17,CN18).....	20
3.11 LCD Interface Connector (CN19)	20
3.12 External Power Connector (CN9).....	22
3.13 Power/HDD LEDS (D5,D12)	22

3.14 Power Reset (CN3)	23
3.15 ATX Power Connector (CN21)	23
3.16 ATX Power button (CN4).....	23
3.17 PC/104 Connection Bus (CN14,CN15)	23
3.18 LAN LED Connector (CN23,CN24)	25
3.19 Power/HDD LEDS Connector(CN22).....	26
4 AWARD BIOS Setup.....	27
4.1 GETTING START	28
4.2 STANDARD CMOS SETUP.....	29
4.3 BIOS FEATURES SETUP	31
4.4 CHIPSET FEATURES SETUP	32
4.5 POWER MANGAGEMENT SETUP	33
4.6 PNP / PCI CONFIGURATION.....	34
4.7 LOAD BIOS DEFAULTS	35
4.8 LOAD SETUP DEFSULTS.....	36
4.9 INTEGRATED PERIPHERALS	37
4.10 SUPERVISOR PASSWORD AND USER PASSWORD	38
4.11 IDE HDD AUTODETECTION	38
4.12 SAVE & EXIT SETUP	40
4.13 EXIT WITHOUT SAVING.....	41
5 SVGA Setup.....	42
5.1 Introduction	42
5.1.1 Chipset.....	42
5.1.2 Display memory.....	42
5.1.3 Display drivers.....	43
5.2 Further Information.....	43

6 PCI Bus Ethernet Interface.....	44
6.1 Introduction	44
Appendix A. Watch-Dog Timer	45
Appendix B. I/O Address Map.....	48
B.1 System I/O Address Map.....	48
B.2 DMA channel assignments	49
B.3 Interrupt assignments.....	49
B.4 1 st MB memory map.....	50

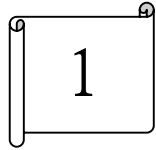

Introduction

WAFER-5823 with two ethernet controller is designed for Network applications. It supports the full functions of an AT-compatible industrial computer on a single board. The WAFER-5823 is equipped with a low-power consumption and high performance GX1 processor on board. It also contains an SDRAM SODIMM socket that can support up to 512MB memory.

The WAFER-5823 provides two Ethernet interface, FDD interface, EIDE interface, Compact Flash Type II, one parallel port, two serial ports RS232, two USB ports, and a 6-pin header PS/2 keyboard/mouse interface. The built-in SVGA/LCD display controller supports both the CRT and LCD display simultaneously. It offers the resolutions of LCD screen up to 1024 x 768 and CRT resolutions up to 1280 x 1024 @ 256 colors. The Flash ROM contains both the system BIOS and the VGA BIOS. Reprogramming the Flash ROM could do the modification, in case of necessary.

1.1 Specifications

***NS 233/266/300 MMX 32-Bit x86 Processor:**

Supports Intel MMX instruction set extension for the acceleration of multi media applications

16 KB unified L1 cache

Five-stage pipelined integer unit

Integrated Floating Point Unit (FPU)

***System memory:** One 144-pin SODIMM socket support up to 512 MB SDRAM

***BIOS:** AWARD 256 KB Flash memory

***Display Controller:** MediaGx processor has applied the UMA technology that provides 1.5-4MB display memory, to be set up by BIOS

Support CRT and TFT LCD displays simultaneously
Support 18-bit TFT LCD panel resolution up to 1024x768 @ 18bpp

Support non-interlaced CRT monitors resolutions up to 1280x1024 @ 256 colors or 1024x768 @ 16bpp

***IDE interface:** The IDE supports two PCI Enhanced IDE hard drives

***Compact Flash disk:** The Compact Flash Storage Card also runs in true IDE mode that is compatible with an IDE disk drive. It can be used with a passive adapter in a Type II socket

***FDD interface:** Support up to two floppy disk drives, 5.25" (360KB and 1.2MB) and/or 3.5" (720KB, 1.44MB, and 2.88MB)

***Serial ports:** Two RS232 ports

***Parallel port:** One Parallel port, supports SPP/EPP/ECP mode

***PS/2 Mouse/Keyboard connector:** A 6-pin header connector is located on the mounting bracket for easy connection to a PS/2 keyboard or PS/2 mouse

***USB interface:** Two USB ports, USB 1.0 compliant

***Watchdog timer:** Can be set by 1-255 seconds period. Reset was generated when CPU did not periodically trigger the timer

***10/100Mbps Ethernet Controller:** Two Realtek RTL8139/Intel GD82559 IEEE802.3 10/100M BASE-T standard Dual auto-sensing interface to 10MBps or 100MBps networks. On board RJ45 connectors provide for easy connection

***E2Key:** A non-volatile 1Kbit EEPROM is provided to retain application critical read/write data

***Power supply:** +5V(4.75V to 5.25V) @2A (typical)

***Operating temperature:** -20-60°C (-4-140°F)

***Dimension:** 5.9" (L) x 4.2" (W) (145mmx102mm)

1.2 What You Have

Before you begin installing the product, please check the following materials are included in the package:

- 1 WAFER-5823 All-in-one single board computer
- 1 CD disk for utility and drivers
- 1 2.5" IDE flat cable (44-pin 2.0mm pitch to 40-pin 2.54mm pitch)
- 1 floppy cable (for 3.5" FDD only)
- 1 serial port cable (RS-232)
- 1 standard D25 connector for parallel cable
- 1 a 6-pin header connector for keyboard and mouse

If any of these items are missing or damaged, contact your distributor or sales representative immediately.

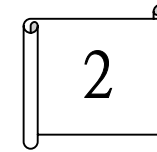

Installation

This chapter gives instructions about how to set up the WAFER-5823 hardware, including directions of setting jumpers and connecting peripherals, switches and indicators. Before installation, please pay attention to the unpacking precautions on the following page for safety.

2.1 WAFER-5823 Block Diagram & Board Layout

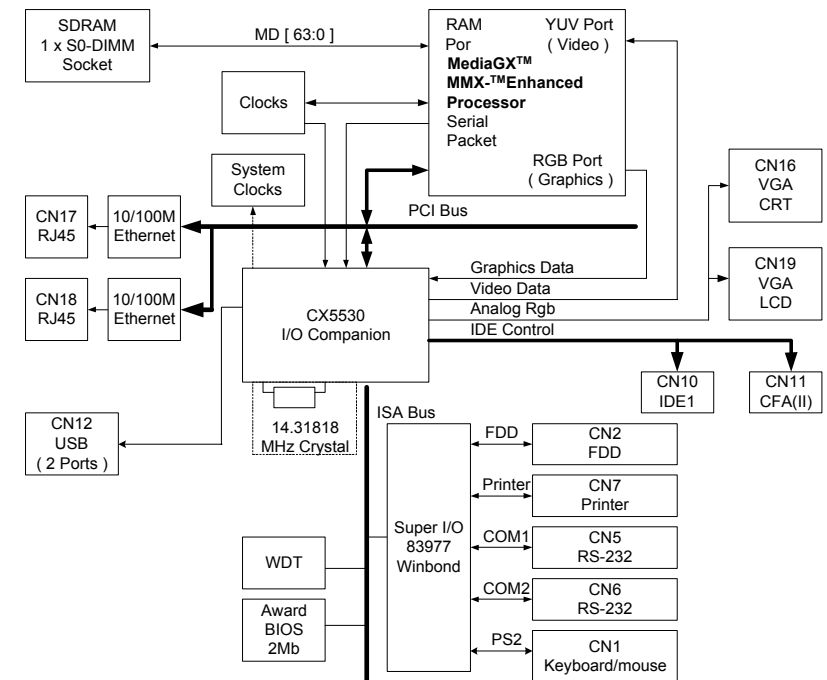

WAFER-5823 Block diagram

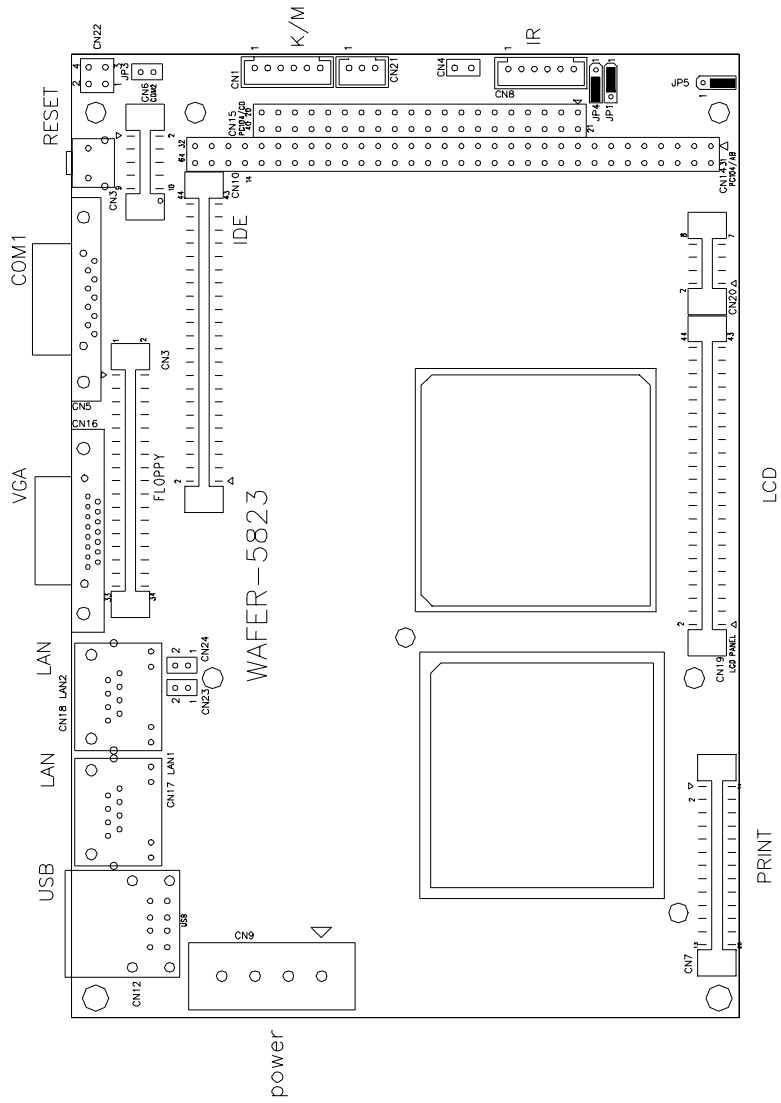

WAFER-5823 Board Layout

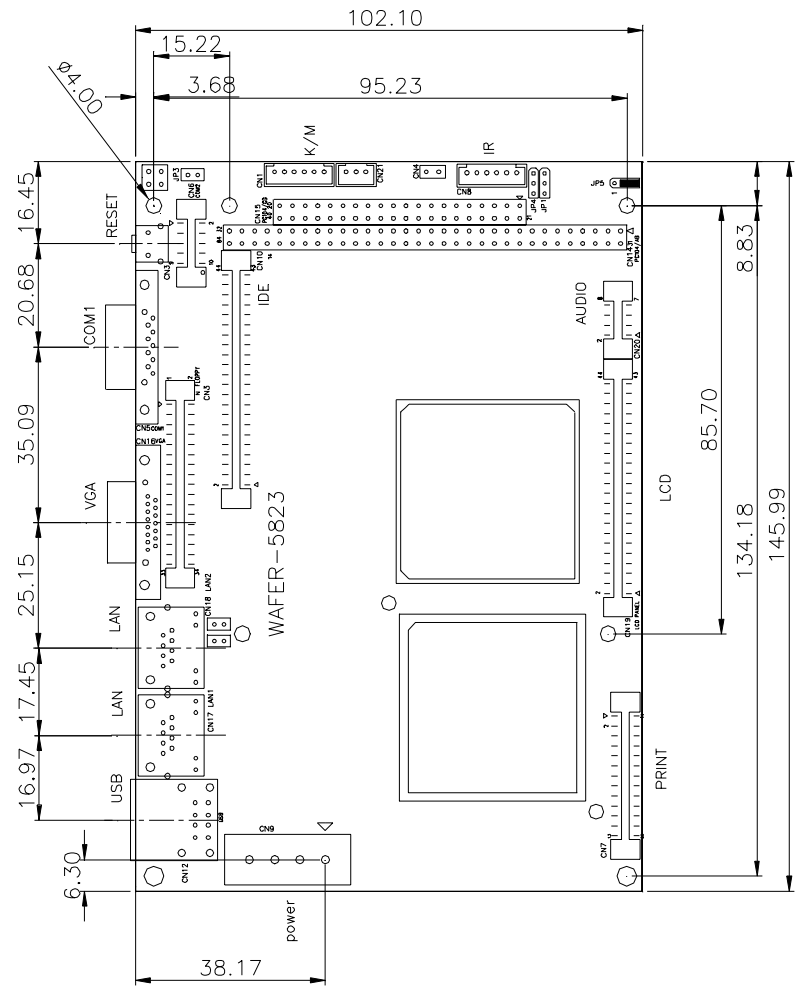

2.2 Unpacking Precautions

Some components of WAFER-5823 SBC are very sensitive to static electric charges and can be damaged by a sudden rush of power. To protect it from unintended damage, be sure to note these precautions:

Ground yourself to remove any static charge before touching the WAFER-5823 SBC. You can do it by using a grounded wrist strap at all times or by frequently touching any conducting materials that is connected to the ground.

Handle your WAFER-5823 SBC by its edges. Don't touch IC chips, leads or circuitry if not necessary.

Do not plug any connector or jumper while the power is on.

2.3 System Memory DRAM

There is one 144-pin SO-DIMM socket to accept 3.3V non-buffered SDRAM. The max Memory size is 512MB.

2.4 Watch-Dog Timer Setting

Reading port 443H enables the Watchdog Timer. It should be triggered before the time-out period ends, otherwise it will assume the program operation is abnormal and will issue a reset signal to start again. Reading port 043/843H disables the Watchdog Timer. Refer to Appendix A for detailed information

- JP4: Watchdog Active Type Setting

JP4	DESCRIPTION
1-2	DISABLE WDT
2-3	RESET WHEN WDT TIME-OUT

2.5 Clear CMOS Setup

If you need to clear the CMOS Setup (for example forgot the password you should clear the setup and then set the password again.), you should close the JP1 about 3 seconds, then open it again. Open JP1 can set back to normal operation mode.

- JP1: Clear CMOS Setup (Reserve Function)

JP1	DESCRIPTION
1-2	Normal Operation
2-3	Clear CMOS Setup

2.6 LCD VCC Voltage / Panel Shift Clock Selector

The LCD interface connector JP5 can provide 5V or 3.3V power supply by selecting the JP5 to meet the different LCD requirement. JP6 is to select Panel Shift Clock.

- JP5: LCD VCC Voltage Selector

JP5	DESCRIPTION
1-2	5V
2-3	3.3V

2.7 Compact Flash Setting

Set the operating mode of CompactFlash disk. This is similar to the operation of hard disk.

JP3	DESCRIPTION
OPEN	SLAVE
CLODE	MASTER

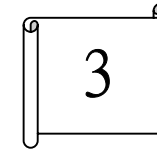

Connection

This chapter describes how to connect peripherals, switches and indicators to the WAFER-5823 board.

3.1 Floppy Disk Drive Connector (CN2)

WAFER-5823 board is equipped with a 34-pin daisy-chain driver connector cable.

CN2: FDC CONNECTOR

PIN NO.	DESCRIPTION	PIN NO.	DESCRIPTION
1	GROUND	2	REDUCE WRITE
3	GROUND	4	N/C
5	GROUND	6	N/C
7	GROUND	8	INDEX#
9	GROUND	10	MOTOR ENABLE A#
11	GROUND	12	DRIVE SELECT B#
13	GROUND	14	DRIVE SELECT A#
15	GROUND	16	MOTOR ENABLE B#
17	GROUND	18	DIRECTION#
19	GROUND	20	STEP#
21	GROUND	22	WRITE DATA#
23	GROUND	24	WRITE GATE#
25	GROUND	26	TRACK 0#
27	GROUND	28	WRITE PROTECT#
29	GROUND	30	READ DATA#
31	GROUND	32	SIDE 1 SELECT#
33	GROUND	34	DISK CHANGE#

3.2 PCI E-IDE Disk Drive Connector (CN10)

For IDE HDD connection. The WAFER-5823 was designed with one 2.0mm connector (CN10), which could be converted to two 2.54mm standard IDE connector via proprietary cable. Using this cable you can attach two IDE hard disk drives to the WAFER-5823.

CN10:44-pin Primary Mini-pitched IDE Interface Connector

- CN10: Primary IDE Interface Connector

PIN NO.	DESCRIPTION	PIN NO.	DESCRIPTION
1	RESET#	2	GROUND
3	DATA 7	4	DATA 8
5	DATA 6	6	DATA 9
7	DATA 5	8	DATA 10
9	DATA 4	10	DATA 11
11	DATA 3	12	DATA 12
13	DATA 2	14	DATA 13
15	DATA 1	16	DATA 14
17	DATA 0	18	DATA 15
19	GROUND	20	N/C
21	IDE DRQ	22	GROUND
23	IOW#	24	GROUND
25	IOR#	26	GROUND
27	IDE CHRDY	28	GROUND
29	IDE DACK	30	GROUND-DEFAULT
31	INTERRUPT	32	N/C
33	SA1	34	N/C
35	SA0	36	SA2
37	HDC CS0#	38	HDC CS1#
39	HDD ACTIVE#	40	GROUND
41	VCC	42	VCC
43	GROUND	44	N/C

3.3 Compact Flash Connector(CN11)

You can attach one Compact Flash Disk to CN11 that occupy the Secondary IDE channel. The CN11 supports both the TYPE II and TYPE I module.

•CN11: Compact Flash Connector (Secondary IDE)

PIN NO.	DESCRIPTION	PIN NO.	DESCRIPTION
1	GROUND	26	VCC-IN CHECK1
2	DATA 3	27	DATA 11
3	DATA 4	28	DATA 12
4	DATA 5	29	DATA 13
5	DATA 6	30	DATA 14
6	DATA 7	31	DATA 15
7	HDC_CS0#	32	HDC_CS1
8	N/C	33	N/C
9	GROUND	34	IOR#
10	N/C	35	IOW#
11	N/C	36	N/C
12	N/C	37	INTERRUPT
13	VCC_COM	38	VCC_COM
14	N/C	39	CSEL
15	N/C	40	N/C
16	N/C	41	HDD_RESET
17	N/C	42	IORDY
18	SA2	43	N/C
19	SA1	44	VCC_COM
20	SA0	45	HDD_ACTIVE#
21	DATA 0	46	N/C
22	DATA 1	47	DATA 8
23	DATA 2	48	DATA 9
24	N/C	49	DATA 10
25	VCC-IN CHECK2	50	GROUND

3.4 Parallel Port (CN7)

This port is usually connected to a printer, The WAFER-5823 includes an on-board parallel port (CN7), accessed through a 26-pin flat-cable connector.

- CN7: Parallel Port Connector

PIN NO.	DESCRIPTION	PIN NO.	DESCRIPTION
1	STROBE#	2	DATA 0
3	DATA 1	4	DATA 2
5	DATA 3	6	DATA 4
7	DATA 5	8	DATA 6
9	DATA 7	10	ACKNOWLEDGE
11	BUSY	12	PAPER EMPTY
13	PRINTER SELECT	14	AUTO FORM FEED #
15	ERROR#	16	INITIALIZE
17	PRINTER SELECT LN#	18	GROUND
19	GROUND	20	GROUND
21	GROUND	22	GROUND
23	GROUND	24	GROUND
25	GROUND	26	N/C

3.5 Serial Ports (CN5, CN6)

The WAFER-5823 offers two high speeds NS16C550 compatible UARTs with Read/Receive 16 byte FIFO serial ports. These ports let you connect to serial devices or a communication network. One 9-pin D-SUB header and one 10-pin header are provided by the WAFER-5823. The detailed pin assignment of the connectors are specified as following tables:

- CN5: Serial Port1 Connector (9-pin D-SUB)

PIN NO.	DESCRIPTION	PIN NO.	DESCRIPTION
1	DCD	2	DSR
3	RX	4	RTS
5	TX	6	CTS
7	DTR	8	RI
9	GND		

- CN6: Serial Port2 Connector (10-pin 2.0mm Header)

PIN NO.	DESCRIPTION	PIN NO.	DESCRIPTION
1	DCD	2	DSR
3	RX	4	RTS
5	TX	6	CTS
7	DTR	8	RI
9	GND	10	N/C

3.6 Keyboard & PS/2 Mouse Connector (CN1)

A 6-pin header connector (CN1) is located on the mounting bracket for easy connection to a keyboard and PS/2 mouse. The card comes with a cable to convert from the 6-pin mini-DIN connector to two 6-pin mini-DIN connector for keyboard and mouse connection

- CN1: 6-pin header Keyboard & Mouse Connector

PIN NO.	DESCRIPTION
1	+5V
2	MOUSE DATA
3	MOUSE CLOCK
4	KEYBOARD DATA
5	KEYBOARD CLOCK
6	GROUND

3.7 USB Port Connector (CN12)

The WAFER-5823 provides two USB interfaces, which give the completed plug and play, for up to 127 external devices.

- CN12: Internal USB Connector

PIN NO.	DESCRIPTION	PIN NO.	DESCRIPTION
1	USBVCC1	1	USBVCC2
2	D1F+	2	D2F+
3	D1F-	3	D2F-
4	USBGND1	4	USBGND2

3.8 IrDA Infrared Interface Port (CN8)

The WAFER-5823 built-in an IrDA port which support Serial Infrared (SIR) or Amplitude Shift Keyed IR (ASKIR) interface. When use the IrDA port have to set SIR or ASKIR model in the BIOS's Peripheral Setup's COM2. Then the normal RS-232 COM2 will be disabled.

- CN8: IrDA connector

PIN NO.	DESCRIPTION
1	VCC
2	FIRRX
3	IRRX
4	GROUND
5	IR-TX
6	CIR

3.9 VGA Connector (CN16)

The WAFER-5823 built-in 15-pin VGA connector accepts the CRT monitor.

- CN16: 15-pin Female Connector

PIN NO.	DESCRIPTION	PIN NO.	DESCRIPTION
1	RED	9	NC
2	GREEN	10	GROUND
3	BLUE	11	NC
4	NC	12	DDCDAT
5	GROUND	13	HSYNC
6	GROUND	14	VSYNC
7	GROUND	15	DDCCLK
8	GROUND		

3.10 LAN RJ45 Connector (CN17,CN18)

The WAFER-5823 built-in two RJ45 LAN connector is for 10/100Mbps Ethernet .

- CN17,CN18: LAN RJ45 Connector

PIN NO.	DESCRIPTION	PIN NO.	DESCRIPTION
1	TX+	6	N/C
2	TX-	7	RX-
3	RX+	8	N/C
4	N/C	9	N/C

3.11 LCD Interface Connector (CN19)

The WAFER-5823 provides a 2x22-pin connector for the LCD flat panel interface.

The WAFER-5823 comes to support TFT LCD panels at following display options: (This is a reference table only , may support more type panels)

Video Display type	Resolution	Example
TFT VGA	640x480, 64K Color, 18bits	Toshiba LTM10C209A
TFT SVGA	800x600, 64K Color, 18bits	Toshiba LTM12C275A
TFT XVGA	1024x768, 64K Color, 18bits	NEC NL10276AC30-04R

The TTL signal connecting interfaces located on CN17. The display options need to be setup manually from BIOS. The BIOS “**Integrated Peripheral**” Setup will allow you to choose display resolution either 640x480 or 800x600 or 1024x768.

- CN19: LCD Interface Connector – only support up to 24 bit LCD. For better display quality, the length of LCD cable should be shorter than 35 cm.

PIN NO.	Description	PIN NO.	Description
1	+12V	2	+12V
3	GND	4	GND
5	+5V	6	+5V
7	FPVVEE	8	GND
9	GND	10	GND
11	BLUE0	12	BLUE1
13	BLUE2	14	BLUE3
15	BLUE4	16	BLUE5

17	GND	18	GND
19	GREEN0	20	GREEN0
21	GREEN2	22	GREEN2
23	GREEN4	24	GREEN4
25	GND	26	GND
27	RED0	28	RED1
29	RED2	30	RED3
31	RED4	32	RED5
33	GND	34	GND
35	SHFCLK	36	FLM
37	M	38	LP
39	GND	40	ENABLK
41	GND	42	N/C
43	+5V	44	5V

3.12 External Power Connector (CN9)

The WAFER-5823 has an on-board external power connector CN9. You can connect power directly to the CPU board.

- CN9: External Power Connector

PIN NO.	DESCRIPTION
1	+12V
2	GROUND
3	GROUND
4	+5

3.13 Power/HDD LEDS (D5, D12)

- D5, D12: Power/HDD Setup

LED	SETTING
-----	---------

D12	Power
D5	HDD

3.14 Power Reset (CN3)

- CN3: Power Reset

PIN NO.	DESCRIPTION
1	RESET
2	GROUND

3.15 ATX Power connector (CN21)

- CN21: ATX Power connector

PIN NO.	DESCRIPTION
1	5VSB
2	GROUND
3	PSON

3.16 ATX Power button (CN4)

- CN4: ATX Power button

PIN NO.	DESCRIPTION
1	ON/OFF
2	GROUND

3.17 PC/104 Connection Bus (CN14, CN15)

The WAFER-5823 PC/104 expansion bus let you attach any kind of PC/104 modules. The PC/104 bus has already become the industrial embedded PC bus standard, so you can easily install over thousands of PC/104 modules from hundreds of vendors in the world. There are two PC/104 connectors on this board: PC/104-64 and PC/104-40.

- CN14: PC/104-64 Connector

PIN NO.	Description	PIN NO.	Description
1	IOCHCK#	33	GND
2	SD7	34	IRSTDRV
3	SD6	35	VCC
4	SD5	36	IRQ9
5	SD4	37	-5V
6	SD3	38	DRQ2
7	SD2	39	-12V
8	SD1	40	ZWS
9	SD0	41	+12V
10	IOCHRDY	42	GND
11	AEN	43	SMEMW#
12	LA19	44	SMEMR#
13	LA18	45	IOW#
14	LA17	46	IOR#
15	SA16	47	DACK3#
16	SA15	48	DRQ3
17	SA14	49	DACK1#
18	SA13	50	DRQ1
19	SA12	51	REFRESH#
20	SA11	52	SYSCLK
21	SA10	53	IRQ7
22	SA9	54	N/C
23	SA8	55	IRQ5
24	SA7	56	IRQ4
25	SA6	57	IRQ3
26	SA5	58	DACK2
27	SA4	59	TC
28	SA3	60	BALE
29	SA2	61	VCC
30	SA1	62	OSC
31	SA0	63	GND
32	GND	64	GND

2	LED+
---	------

- CN15: PC/104-40 Connector

PIN NO.	Description	PIN NO.	Description
1	GND	21	GND
2	MCS16#	22	SBHE#
3	IOCS16#	23	LA23
4	IRQ10	24	LA22
5	IRQ11	25	LA21
6	IRQ12	26	LA20
7	IRQ15	27	LA19
8	IRQ14	28	LA18
9	DACK0#	29	LA17
10	DRQ0	30	MEMR#
11	DACK5#	31	MEMW#
12	DRQ5	32	SD8
13	DACK6#	33	SD9
14	DRQ6	34	SD10
15	DACK7#	35	SD11
16	DRQ7	36	SD12
17	VCC	37	SD13
18	MASTER#	38	SD14
19	GND	39	SD15
20	GND	40	GND

3.18 LAN LED Connector (CN23,24)

- CN23: LAN link LED connector

PIN NO.	DESCRIPTION
1	LED-
2	LED+

- CN24: LAN link LED connector

PIN NO.	DESCRIPTION
1	LED-

3.19 Power/HDD LEDS Connector (CN22)

- CN22: Power/HDD LEDS connector

PIN NO.	DESCRIPTION
1	Power LED-
2	Power LED+
3	HDD LED-
4	HDD LED+



AWARD BIOS Setup

WAFER-5823 uses the AWARD PCI/ISA BIOS for system configuration. The AWARD BIOS setup program is designed to provide maximum flexibility in configuring the system by offering various options that may be selected to meet end-user requirements. This chapter is written to assist you in the proper usage of these features.

4.1 GETTING START

When you turn on the power button, the BIOS will enter the Power-On-Self-Test routines. These routines will be executed for system test and initialization and system configuration verification. After the POST routines are completed, the following message appears:

" Hit DEL if you want to run SETUP"

To access AWARD BIOS SETUP UTILITY, press key. The following screen will be displayed at this time:

```
AWARD BIOS SETUP UTILITY
CMOS SETUP HELP
BIOS SETUP HELP

STANDARD CMOS SETUP          INTEGRATED PERIPHERALS
BIOS FEATURES SETUP          SUPERVISOR PASSWORD
CUSTOM FEATURES SETUP        USER PASSWORD
POWER MANAGEMENT SETUP      IDE HDD AUTO DETECTION
PHYSICAL CONFIGURATION       S.M.A.R.T. SETUP
BIOS SECURITY FEATURES        EXIT SETUP SCREEN

F10 - Save & Exit Setup      F11 - Select Item
F12 - Help                   Esc - Exit

```

4.2 STANDARD CMOS SETUP

The Standard CMOS Setup is used for basic hardware system configuration. The main function is for Date/Time setting and Floppy/Hard Disk Drive setting.

```

      (DEL) (F1) (F2) (F3) (F4) (F5)
      STANDARD CMOS SETUP
      (F6) (F7) (F8) (F9) (F10) (F11) (F12)

-----
Date (mm/dd/yy)  Tue, Apr 26, 2000
Time (hh:mm:ss)  11:35:55

Hard Disks:
Primary Master  0000  0  0  0  0  0  0  0  0000
Primary Slave   0000  0  0  0  0  0  0  0  0000
Secondary Master 0000  0  0  0  0  0  0  0  0000
Secondary Slave  0000  0  0  0  0  0  0  0  0000

Drive 0: 1.44M 2.5 in.
Drive 1: none

Video: EGA/VGA
Halt On: All but Keyboard

ESC  Quit      F1  Help
F2  Load      F3  Load Defaults
F4  Save      F5  Save Defaults
F6  Exit      F7  Exit Without Saving
F8  Exit      F9  Exit Without Saving
F10 Exit      F11 Exit Without Saving
F12 Exit      F12 Exit Without Saving
-----

```

Please refer the following screen for this setup.

To set the Date, for example, press either the arrow or <Enter> button on your keyboard to select one of the fields (Month, Date or Year) then press either <PgUp> or <PgDn> to increase or decrease the value of that field. Do the same steps for Time setting.

For IDE hard disk drive setup, please check the following possible setup procedure:

1. Use the Auto setting for detection during boot-up.
2. Use the IDE HDD AUTO DETECTION in the main menu; the computer will automatically detect the HDD specifications.
3. Manually enter the specifications by yourself from the "User" option.

Note:

If you need more information on any particular field, just highlight it then press <F1> button. A pop-up window will come out to give you more information on that field.

4.3 BIOS FEATURES SETUP

This BIOS Features Setup is designed for the 'fine tuning' of your system in order to improve its performance. As for normal operation, you don't have to change any default setting. The default setting is pre-set for most reliable operation.

```

ROM BIOS Release Date: 12/06/2004
ROM BIOS Version: 6.00
Award Software, INC.
  
```

Video BIOS Shadow	Disabled	Video	8287	Shadow	Enabled
PCI Interrupts Control	Enabled	18000	0504	Shadow	Disabled
Auto Power Up Self Test	Enabled	10000	0504	Shadow	Disabled
Soft Power Off Delay	Disabled	00000	0504	Shadow	Disabled
Soft Suspend	Full NPS1	00000	0504	Shadow	Disabled
Smart Power Entry	Enabled	00000	0504	Shadow	Disabled
Soft Up Delay	Enabled	00000	0504	Shadow	Disabled
Soft Up Harddisk Status	On				
Soft Up System Speed	Slow				
Auto HDD Detection	Yes				
Memory Parity Check	Enabled				
Typical State Softing	Disabled				
Typical State Memory	6				
Typical State Delay	299				
Security Option	Setup	ESC	Quit	Yes	Setup Item
IDE/ATA/ATAPI Storage	Disabled	11	0x3F	00000000	Master
IDE Select for IDE0/1/2/3/4	Auto	12	0x3F	00000000	Color
Support for IDE for ATN 95	Yes	13	0x3F	00000000	Color
		14	0x3F	00000000	Color
		15	0x3F	00000000	Color

4.4 CHIPSET FEATURES SETUP

This setup function works mostly on board's chipset. This option is used to change the chipset's configuration. Please, carefully change any default setting, otherwise the system will run unstable.

```

ROM BIOS Release Date: 12/06/2004
ROM BIOS Version: 6.00
Award Software, INC.
  
```

SDRAM CAS Latency	3.0
SDRAM RAS to CAS Delay	4
DRAM Refresh Rate (1KB)	5
DRAM Refresh Rate (1KB)	5
ISA Load/Save	Disabled

F1: Quit F2: Setup Item
 F3: Help F4: Save & Exit
 F5: Load Values (Default)
 F6: Load BIOS Defaults
 F7: Load Setup Defaults

SDRAM Clock Ratio Div By: To select the operating clock of SDRAM module. If you have GX1-300 CPU on board, the ratio is set to 4, then the clock would be:

$$300 / 4 = 75 \text{ MHz}$$

In order to maintain the stability of CPU board, remember not set the clock over 80 MHz, although higher frequency means higher performance.

4.5 POWER MANAGEMENT SETUP

Power Management Setup helps user to handle the WAFER-5823 board's "green" function. This feature can shut down the video display and hard disk to save energy, for example. The power management setup screen is as following

```

IBM PC/XT/PC Plus Configuration
POWER MANAGEMENT SETUP
*****

Power Management      Enabled  [F5] Disabled  [F6]
    ** PM Timer, **
Auto Mode            Enabled  [F7] Disabled  [F8]
Standby Mode         Enabled  [F9] Disabled  [F0]
Hard Disk Power Down Enabled  [F1] Disabled  [F2]
Auto Mode (IDE)      Off      [F3]
Hard Disk Auto Cycle Off      [F4]

    [ESC] Quit      [F10] Select Item
    [F1] Help      [F11] Help
    [F5] Old Values [F12] Restore
    [F6] Load BIOS Defaults
    [F7] Load Setup Defaults
    
```

4.6 PNP / PCI CONFIGURATION

This menu is used to assign certain IRQ to your PNP/PCI devices manually.

```

IBM PC/XT/PC Plus Configuration
PNP/PCI Configuration
*****

PNP OS Installed      No      PCI IRQ Assigned By  Level
Resources Controlled By Auto
Reset Configuration Data Enabled

    [ESC] Quit      [F10] Select Item
    [F1] Help      [F11] Help
    [F5] Old Values [F12] Restore
    [F6] Load BIOS Defaults
    [F7] Load Setup Defaults
    
```

PNP OS Installed: if you install Plug and Play operating system (OS), the OS will reassign the interrupt if you select Yes in this field. If you install a non-Plug and Play OS or if you want to prevent reassigning of interrupt settings, select No in this field.

Resources Controlled By: select *Auto* if you want the computer to assign the IRQs automatically and vice versa.

Reset Configuration Data: *Enabling* this field means you allow the configuration data to be reset.

IRQ-xx assigned to: these fields show whether a PCI/ISA uses certain IRQ.

4.7 LOAD BIOS DEFAULTS

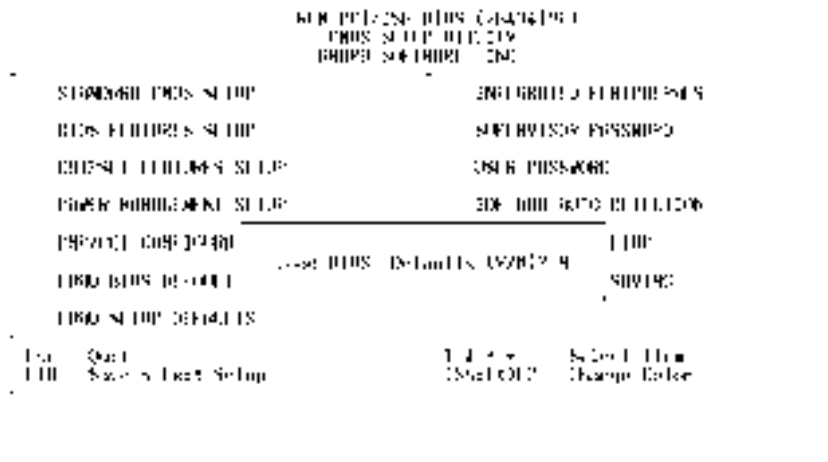

If you select 'Y' to this field, the BIOS Defaults will be loaded except Standard CMOS SETUP. The default settings are not optimal and turning all high performance into disabled condition. Select 'N' to abort. *Suggestion: for the first time or for our primary user, we suggest you to use LOAD SETUP DEFAULTS because it is the safest mode for your system.*

4.8 LOAD SETUP DEFAULTS

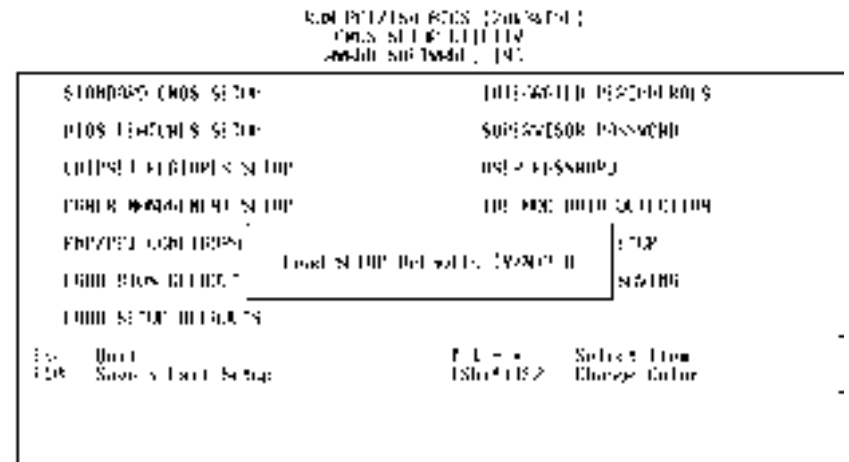

If you select 'Y' to this field, the Setup Defaults will be loaded except Standard CMOS SETUP. The default settings are optimal configuration settings for your system.

4.9 INTEGRATED PERIPHERALS

NON-PCI/ISA BUS (200,0,0,0)			
INTEGRATED PERIPHERALS			
ONBOARD SOFTWARE			
IDE HDD Block Mode	Enabled		
Primary IDE Channel	Enabled	Onboard Parallel Port	20MB/295
Master Device PIO Mode	Auto	Parallel Port Mode	SPP
Slave Device PIO Mode	Auto		
Secondary IDE Channel	Enabled		
Master Device PIO Mode	Auto		
Slave Device PIO Mode	Auto		
IDE Primary Master (000)	Auto		
IDE Primary Slave (000)	Auto		
IDE Secondary Master (000)	Auto		
IDE Secondary Slave (000)	Auto		
KB Controller/Block	Normal	Multiple Monitor Support	MS-DOS
Onboard VGA Controller	Enabled		
Onboard Serial Port 1	20MB/295	Video Memory Size	4.0M
Onboard Serial Port 2	20MB/295	Full Panel Status	PS-2
LBMT Mode Select	Normal	Full Panel Resolution	800x600

This option is used to assign Onboard I/O, IRQ, and DMA etc. If you don't know how to configure them, just press <F7> to load Setup Defaults.

- **Multiple Monitor Support -- No Onboard, PCI first, M/B first**
To select the primary VGA for multiple monitor support in WINDOWS.
- **Video Memory Size -- 1.5M, 2.5M, 4.0M**
To select the size of video memory. It makes use of system memory for display.

4.10 SUPERVISOR PASSWORD AND USER PASSWORD

PASSWORD

Supervisor Password sets a password that is used to protect your system and Setup Utility. Supervisor Password has higher priority than User Password. Once you setup the password, the system will always ask you to key-in password every time you enter the BIOS SETUP. If you enter the BIOS SETUP with Supervisor Password, you can choose every setup/option on the main menu but with User Password, you can only choose three setup/options (USER PASSWORD, SAVE & EXIT SETUP and EXIT WITHOUT SAVING). To disable these passwords, enter the BIOS SETUP room with Supervisor Password and then just press the <Enter> key instead of entering a new password when the 'Enter Password' prompt pop-up.

N.B.: if you forget the password, do the Clear/Reset CMOS procedure (see Section 2.5 Clear CMOS Setup)

4.13 EXIT WITHOUT SAVING

Select this option if you want to exit the Setup without saving the changes that you made. Just simply press <Enter> key and you will exit the BIOS SETUP without saving the changes.

```

                                IBM PC/AT compatible
                                BIOS SETUP utility
                                HP/PS/2 MOUSE - 100

STANDARD CMOS SETUP             INTEGRATED PERIPHERALS
BIOS FEATURES SETUP            SUPERVISOR PASSWORD
ADVANCED BIOS FEATURES SETUP    USER PASSWORD
POWER MANAGEMENT SETUP         ACPI BIOS METHOD DETECTION
PHYSICAL DRIVES                [TAB]
LOAD BIOS DEFAULT              [TAB]
LOAD SETUP DEFAULTS            [TAB]
[Esc] Quit                    [F10] Save & Exit
[F10] Save & Exit Setup       [Shift+F2] Select Item
                               [Enter] Change Color

```

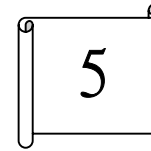

SVGA Setup

5.1 Introduction

The WAFER-5823 is equipped with on-board VGA interface. The description below is its specifications and features:

5.1.1 Chipset

The WAFER-5823 uses a NS CX5530A chipset as its SVGA controller. It is compatible with many common 18-bit LCD displays and traditional analog CRT monitors. The VGA BIOS supports LCD. Besides, it also accepts interlaced and non-interlaced analog monitors (color and monochrome VGA) with high-resolution quality while maintaining complete IBM VGA compatibility. But digital monitors (i.e. MDA, CGA, and EGA) can be NOT supported. Multiple frequency (multisync) monitors are operated as if they were analog monitors.

5.1.2 Display memory

Having 1.5 ~ 4 MB UMA memory, the VGA controller can make CRT displays or color panel displays perform with resolutions up to 1024 x 768 at 64 K colors. The display memory can be modified

up to 4 MB in BIOS for true-color resolution of 1024 x 768.

5.1.3 Display drivers

1. Win95, 98 drivers (VGA) in CD rom
 \ Vga \ MediaGX \ Win9x
2. WinNT4.0 drivers in CD rom
 \ Vga \ MediaGX \ Nt40

5.2 Further Information

For more detailed information about the PCI/SVGA installation in your WAFER-5823, including driver updates, troubleshooting instructions, please refer to the following webs that provide some resources you may need. If not find the information you need, please contact with your local contributor or ICP support team:

ICP web site: www.iei.com.tw

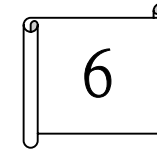

PCI Bus Ethernet Interface

6.1 Introduction

The WAFER-5823 provides three high performance 32-bit Ethernet chipset that is completely compliant with IEEE 802.3 100 Mbps CSMA/CD standards. It is both 100Base-T and 10Base-T compatible. The major network operating system fits it. The medium type can be set up via the RSET8139.exe program included on the utility CD.

The Ethernet port supplies three standard RJ-45 connector on board. To utilize the network boot feature is by incorporating the boot ROM image files for the appropriate network operating system. The boot ROM BIOS files are combined with system BIOS, which can be enabled/disabled in the BIOS setup.

The 8139x utility tools are in the following directory of CD rom

\ Lan \ Realtek \ 8139c \

Appendix A. Watchdog Timer

The Watchdog Timer is a device to ensure that standalone systems can always recover from catastrophic conditions that cause the CPU to crash. This condition may have occurred by external EMI or a software bug. When the CPU stops working normally, hardware on the board will perform hardware reset (cold boot) to bring the system back to a known state.

Three I/O ports control the Watchdog Timer.

443	Write	Set Watchdog Time period
443 (hex)	Read	Enable the refresh the Watchdog Timer
043/843 (hex)	Read	Disable the Watchdog Timer

Prior to enable the Watchdog Timer, user has to define Timer first. The output data is a value of time interval and the range of the value is from 01(hex) to FF (hex) and time interval 1 sec to 255 sec.

Data	Time Interval
01	1 sec
02	2 sec
03	3 sec
04	4 sec
.	.
.	.
.	.
FF	255 sec

This will enable and activate the countdown timer which will eventually time out and reset the CPU to ensure that this reset condition does not occur, the Watch-Dog Timer must be periodically refreshed by reading the same I/O port 043/843H and 443H. This must be done within the time out period that is selected by software, please refer to the example program.

A tolerance of at least 5% must be maintained to avoid unknown routines within the operating system (DOS), such as disk I/O that can be very time consuming. Therefore if the time-out period has been set to 10 seconds, the I/O port 443H must be read within 7 seconds.

Note: when exiting a program it is necessary to disable the Watchdog Timer, otherwise the system will reset.

Example assembly program:

```
TIMER_PORT = 443H
```

```
TIMER_START = 443H
```

```
TIMER_STOP = 843H
```

```
;;INITIAL TIME PERIOD COUNTER
```

```
MOV DX, TIME_PORT
```

```
MOV AL,8:    ;;8 SECONDS
```

OUT DX,AL

::ADD YOUR APPLICATION HERE

MOV DX, TIMER_START

IN AL, DX. ;;START COUNTER

;ADD YOUR APPLICATION HERE

W_LOOP:

MOV DX, TIMER_STOP

IN AL, DX

MOV DX, TIMER_START

IN AL, DX. ; RESTART COUNTER

; ADD YOUR APPLICATION HERE

CMP EXIT_AP, 0

JNE W_LOOP

MOV DX, TIMER_STOP

IN AL, DX

::EXIT AP

Appendix B. I/O Address Map

B.1 System I/O Address Map

I/O Address Map	Description
000-00F	DMA controller #1
020-021	Interrupt controller # 1, master
022-023	Chipset address
040-043	System timer
060-060	Standard 101/102 keyboard controller
061-061	System speaker
064-064	Standard 101/102 keyboard controller
070-07F	Real time clock, NMI controller
080-0BF	DMA page register
0A0-0BF	Interrupt Controller # 2
0C0-0DF	DMA Controller # 2
0F0-0F0	Clear math coprocessor busy
0F1-0F1	Reset math coprocessor
0F8-0FF	Math coprocessor
1F0-1F7	BUS master PCI IDE controller
278-27F	Reserved
2F8-2FF	Serial Port 2
378-37F	Parallel Printer Port 1
3B0-3DF	Cyrix Graphic Adapter
3F0-3F7	Floppy Disk Controller
3F8-3FF	Serial Port 1
443	Watch dog timer enable
043/843	Watch dog timer disable

B.2 DMA channel assignments

Channel	Function
0	Available
1	Available
2	Standard floppy disk controller
3	Parallel port*
4	Cascade for DMA controller 1
5	Available
6	Available
7	Available

* parallel port DMA default setting: DMA 3

parallel port DMA select: DMA 1 or 3

Ethernet IRQ is automatic set by the system

B.4 1st MB memory map

Address	Description
F000h-FFFFh	System BIOS
EF00h-EFFFh	Expansion ROM*
C800h-EEFFh	Unused
C000h-C7FFh	VGA BIOS*
B000h-BFFFh	VGA DRAM
A000h-AFFFh	VGA DRAM
0000h-9FFFh	Base memory

* Default setting

B.3 Interrupt assignments

Interrupt #	Interrupt source
NMI	Parity error detected
IRQ 0	System timer
IRQ 1	Keyboard
IRQ 2	Interrupt from controller 2 (cascade)
IRQ 3	Serial communication port 2
IRQ 4	Serial communication port 1
IRQ 5	Available
IRQ 6	Standard floppy disk controller
IRQ 7	Parallel port (print port)
IRQ 8	Real-time clock
IRQ 9	Available
IRQ 10	Available
IRQ 11	Available
IRQ 12	PS/2 mouse
IRQ 13	Numeric data processor
IRQ 14	Fixed primary IDE controller
IRQ 15	Fixed secondary IDE controller