

Product Specification

Gleichmann & Co. Electronics GmbH
 Productmarketing Displays & Systems
 Industriestr. 16, D- 76297 Stutensee
 Tel :07249-910-0, Fax: 07249-4232
<http://www.msc-ge.com>

SPECIFICATION

For

APPROVAL

- () Preliminary Entry Level Specification
 () Final Specification

Title	10.4" VGA TFT LCD
-------	-------------------

BUYER NAME	
MODEL NAME	

SUPPLIER	LG LCD Inc.
MODEL NAME	LP104V2-W

SIGNATURE	DATE
_____/_____ 	_____
_____/_____ 	_____
_____/_____ 	_____

APPROVED BY	DATE
_____ /G.Manager	_____
REVIEWED BY	
_____ /S.Engineer	_____
PREPARED BY	
_____/_____ Engineer	_____

Please return 1 copy for our confirmation with your signature and comments.

Product Engineering Dept.
 LG LCD Inc.

Product Specification

CONTENTS

NO.	ITEM	Page
-	COVER	1
-	CONTENTS	2
-	RECORD of REVISION	3
1.	GENERAL DESCRIPTION	4
2.	MAXIMUM RATINGS	5
3.	ELECTRICAL SPECIFICATIONS	5
4.	OPTICAL SPECIFICATIONS	6
5.	ENVIRONMENT	7
6.	INTERFACE PIN CONFIGURATION	8
7.	SIGNAL TIMING SPECIFICATIONS	9
8.	SIGNAL TIMING WAVE FORMS	10
9.	COLOR INPUT DATA REFERENCE	11
10.	POWER ON/OFF SEQUENCE	12
11.	MECHANICAL CHARACTERISTICS	13
12.	COSMETICS	14
13.	SAFETY	15
14.	PACKAGING	15
15.	SMOKE FREE DESIGN	15
16.	PERFORMANCE	15
17.	PRECAUTIONS	16-17
-	APPENDIX	18-19

Product Specification

Record of Revision

DATE AND VERSION	DESCRIPTION

Product Specification
1. General Description

The LG LCD Inc. model LP104V2-W LCD is a Color Active Matrix Liquid Crystal Display with an integral Cold Cathode Fluorescent Tube (CCFT) back light system. The matrix employs a-Si Thin Film Transistor as the active element. It is a transmissive type display operating in the normally white mode. This TFT-LCD has a 10.4 inch diagonally measured active display area with VGA resolution (480 vertical by 680 horizontal pixel array). Each pixel is divided into Red, Green and Blue sub-pixels or dots which are arranged in vertical stripes. Gray scale or the brightness of the sub-pixel color is determined with a 6-bit gray scale signal for each dot, thus, presenting a palette of more than 262,144 colors.

The LP104V2-W LCD is intended to support applications where wide viewing angle, low power are critical factors and graphic displays are important. In combination with the vertical arrangement of the sub-pixels, the LP104V2-W characteristics provide an excellent flat panel display for office automation products such as Notebook PC.

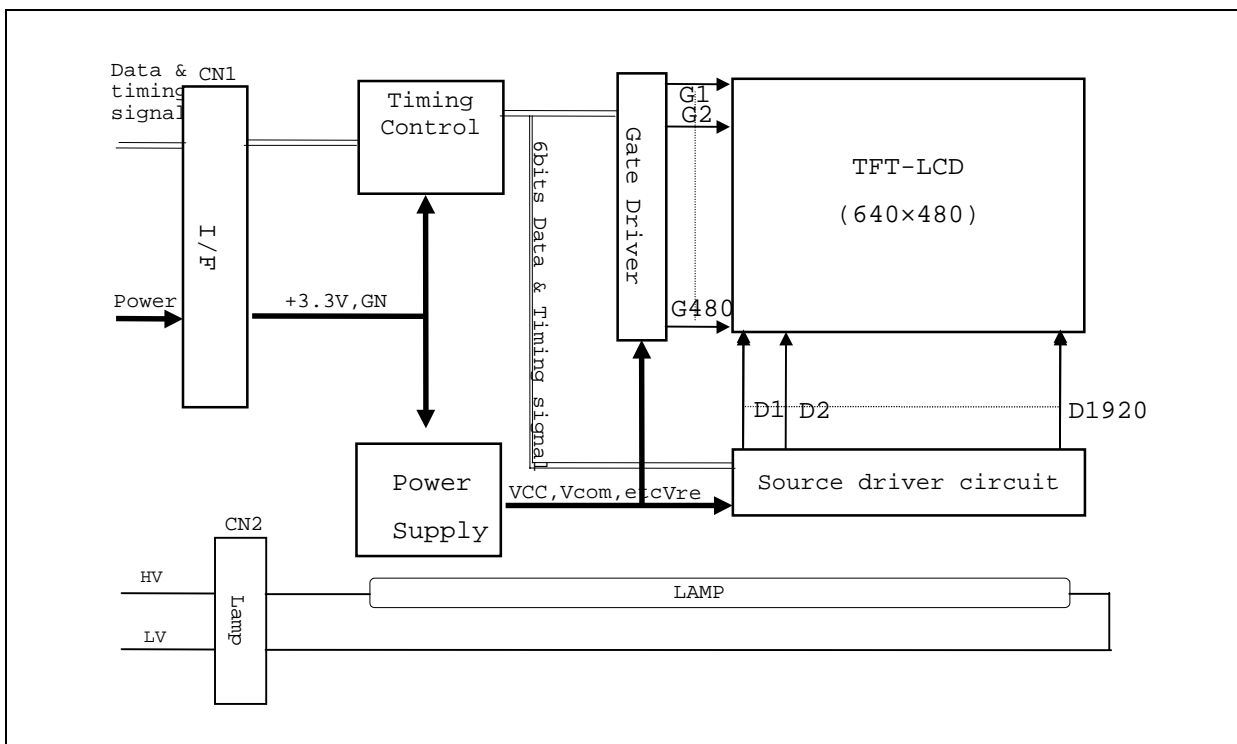
General Display Characteristics

The following are general feature of the model LP104V2-W LCD;

Active display area	10.4 inches(26.42cm) diagonal
Outsize dimensions	246.5(H) × 179.4(V) × 8.0(W) mm(typ)
Pixel pitch	0.33 mm × 0.33 mm
Pixel format	640 horiz. By 480 vert. pixels
	RGB stripe arrangement
Color depth	6-bit, 262,144 colors
Display operating mode	transmissive mode, normally white
Surface treatments	hard coating(3H), anti-glare treatment of the front polarizer
Weight	415g (Typ.)

Product Specification

2. Maximum Ratings

The following are maximum values which, if exceeded, may cause faulty operation or damage to the unit.

Table 1 ABSOLUTE MAXIMUM RATINGS

Parameter	symbol	Values		Units	NOTES
		Min.	Max.		
Power Input Voltage	V_{DD}	3.0	3.6	Vdc	at 25•
Operating Temperature	T_{OP}	0	+50	•	
Storage Temperature	T_{ST}	-20	+60	•	1

Notes: 1. The Relative Humidity must not exceed 80% non-condensing at temperatures of 50• or less.

At temperatures greater than 40•, the wet bulb temperature must not exceed 49•.

2. Under no condition should the unit be exposed to corrosive chemicals.

3. Electrical Specifications

The LP104V2-W requires two power inputs. One is employed to power the LCD electronics and to drive the voltages to drive the TFT array and liquid crystal. The second input which powers the backlight CCFT, is typically generated by an inverter. The inverter is an external unit to the LCD.

Table 2 ELECTRICAL CHARACTERISTICS:

Parameter	Symbol	Values			Units	Notes
		Min.	Typ.	Max.		
MODULE:						
Power Supply Input	V_{DD}	3.0	3.3	3.6	Vdc	
Voltage	I_{DD}	-	170	227	mA	1
Power Supply Input	P_{DD}	-	0.56	0.75	Watts	
Current		-	-	-		
Power Consumption	V_{IH}	2.0	-	V_{DD}	V	2
Ripple/Noise	V_{IL}	V_{SS}	-	0.8	V	2
Logic Input Level, High						
Logic Input Level, Low						
	I_t	2.0	5.5	6.0	mA	
BACK LIGHT	V_f	490	505	630	V _{RMS}	
Lamp current	F_f	40	60	80	KHz	3
Lamp voltage	V_k	-	-	845	V _{RMS}	25±2•
Lamp frequency		-	-	1015	V _{RMS}	0±2•
Established starting voltage	L_t	20000	-	-	Hrs	
	PBL	1.3	2.8	2.9	Watts	4
Lamp life time						
Power Consumption						

Notes: 1. The current draw and power consumption specified is for 3.3 Vdc at 25•, fv at 60Hz and black

signal displayed.

2. Logic levels are specified for V_{DD} of 3.3 Vdc at 25 •. The values specified apply to all logic inputs; Hsync, Vsync, clock, data signals, etc.

3. Lamp frequency may produce interference with horizontal sync. frequency , and may cause beat on the display. Therefore lamp frequency shall be detached as much as from the horizontal sync. and from the harmonics of horizontal synchronous to avoid interference.

4. DC/AC inverter for backlight is not built in this module.

Back light power consumption shown above does not concern the efficiency of the inverter.

4. Optical Specifications

Optical characteristics are determined after the unit has been 'ON' and stable for

Product Specification

approximately 30 minutes in a dark environment at 25°. The values specified are at an approximate distance 50cm from the LCD surface at a viewing angle of Φ and θ equal to 0°.

Appendix A presents additional information concerning the specified characteristics.

Table 3 OPTICAL CHARACTERISTICS

Parameter	Symbol	Values			Units	Notes	
		Min.	Typ.	Max.			
Contrast Ratio	CR	100	150	-		1	
Surface Brightness	Bsf	180	200	-	cd/m ²	2	
Brightness Variation	B _v	-	-	1.45		3	
Response Time	Tr				msec	4	
Time	Rise	Tr _R	30				
Time	Decay	Tr _D	50				
CIE Color Coordinates	Red	x _R	0.513	0.543	0.573	±0.03	
		y _R	0.304	0.334	0.364		
		x _G	0.287	0.317	0.347		
Green	Blue	y _G	0.470	0.500	0.530		
		x _B	0.126	0.156	0.186		
		y _B	0.121	0.151	0.181		
White	Blue	x _W	0.292	0.322	0.352		degree, °
		y _W	0.309	0.339	0.369		
Viewing Angle	x axis, right (•=0°) x axis, left (•=180°) y axis, up(•=90°) y axis, down (•=270°)	•x	70				
		•x	70				
		•y	45				
		•y	50				
Flicker						6	

- Notes
1. Contrast Ratio (CR) is defined mathematically as :

$$\frac{\text{(Surface Brightness with all white pixels)}}{\text{(Surface Brightness with all black pixels)}}$$
 2. Surface brightness is measured on the LCD surface 50cm from the surface with all pixels displaying white. For more information see Appendix A - 1.
 3. The variation in surface brightness, SB_v is determined by measuring B_{0N} at each test position 0 through 5, and then dividing the maximum B_{0N} of 5 points luminance by minimum B_{0N} of 5 points luminance. For more information see Appendix A - 2.

$$SB_v = \frac{\text{Maximum (} B_{0N0}, B_{0N1}, \dots, B_{0N5} \text{)}}{\text{Minimum (} B_{0N0}, B_{0N1}, \dots, B_{0N5} \text{)}}$$
 4. Response time is the time required for the display to transition from white to black (Rise Time, Tr_R) and from black to white (Decay Time, Tr_D). For additional information see Appendix A - 3.
 5. Viewing angle is the angle at which the contrast ratio is greater than 5. The angles are determined for the horizontal or x axis and the vertical or y axis with respect to the z axis which is normal to the LCD surface. For more information see Appendix A - 4.
 6. When the LCD is refreshed at 60Hz rate with the backlight on, there are no noticeable flicker at line by line pattern (gray level 0/31) when the screen is viewed with naked eye.

Product Specification
Table 4 Luminance of Grey Level

Gray Level	Luminance (%) (min)	Luminance (%) (max)
L0	0.0	1.0
L7	0.0	3.0
L15	0.0	6.0
L23	1.5	15.0
L31	5.0	38.0
L39	20.0	70.0
L47	50.0	90.0
L55	80.0	98
L63	100	100

5. Environment

- 5.1 Altitude : operating 0 - 10,000 feet (3048m)
storage/shipment 0 - 40,000 feet (12192m)
- 5.2 Corrosive gas : use at indoor & outdoor in a big city.
- 5.3 Environment test condition

No.	Test ITEM	Conditions
1	High temperature storage test	Ta = 60• 240h
2	Low temperature storage test	Ta = -20• 240h
3	High temperature & high humidity operation test	Ta = 40• 95%RH 240h (no condensation)
4	High temperature operation test	Ta = 50• 240h
5	Low temperature operation test	Ta = 0• 240h
6	Vibration test (non-operating)	- Sine wave, 10 to 500Hz, 1.5G, 0.5oct/min, 3axis, - Random Truck : 6-12-18-42-80-200Hz 0.5Grms, 30min. 3axis - Random Air : 6-18-200-500Hz 2.1Grms, 30min. 3axis
7	Shock test (non-operating)	- half sine wave, 180G, 2ms, one shock of each six faces (i.e. run 180G 2ms for all six faces.)

{Result Evaluation Criteria}

There should be no change which might affect the practical display function when the display quality test is conducted under normal operating condition.

Product Specification

6. Interface Pin Configuration

* Used connector : DF9B-31P-1V(HIROSE), Matching side : DF9B-31S-1V(HIROSE)

Table 5 INTERFACE PIN CONFIGURATION

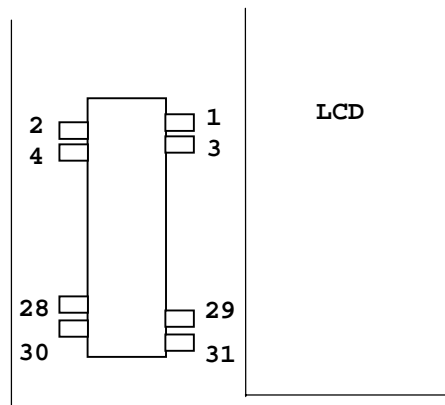
Pin	Symbol	Description	Notes
1	GND	Ground	<p style="text-align: center;">I/F PIN ARRANGEMENT (Transparent view)</p>  <p style="text-align: center;">LCD</p> <p>* NC (30, 31pin) should be electrically opened during operation.</p> <p style="text-align: center;">TOP VIEW</p> <p>* The metal top case is connected to GND.</p> <p>* All GND(ground) pins should be connected together and to Vss which also be connected to the LCD's metal frame.</p> <p>* All Vdd(power input) pins should be connected together.</p>
2	CLK	Data clock	
3	Hsync	Horizontal sync.	
4	Vsync	Vertical sync.	
5	GND	Ground	
6	R0	Red data(LSB)	
7	R1	Red data	
8	R2	Red data	
9	R3	Red data	
10	R4	Red data	
11	R5	Red data(MSB)	
12	GND	Ground	
13	G0	Green data(LSB)	
14	G1	Green data	
15	G2	Green data	
16	G3	Green data	
17	G4	Green data	
18	G5	Green data(MSB)	
19	GND	Ground	
20	B0	Blue data(LSB)	
21	B1	Blue data	
22	B2	Blue data	
23	B3	Blue data	
24	B4	Blue data	
25	B5	Blue data(MSB)	
26	GND	Ground	
27	DTMG	Data timing signal	
28	VDD	Power supply +3.3V	
29	VDD	Power supply +3.3V	
30	NC	No connection	
31	NC	No connection	

The backlight interface connector is a model BHR-03VS-1, manufactured by JST. The mating connector part number is SM02(0.8)B-BHS-1-TB or equivalent. The pin configuration for the connector is shown in the table below.

Table 6 BACKLIGHT CONNECTOR PIN CONFIGURATION

Pin	Symbol	Description	Notes
1	HV	High voltage input	1
2	NC	NC	
3	LV	Low voltage input	

Notes: 1. The HV pin(wire) is colored pink. The LV pin(wire) color is white.
2. The Lamp housing should be common with ground(metal frame).

Product Specification

7. Signal Timing Specification

This is the signal timing required at the input of the ASIC inside module. All of the interface signal timing should be satisfied with the following specifications for it's proper operation.

Table 7 Timing Table

ITEM		Symbol	MIN.	TYP.	MAX.	UNIT	NOTE
DCLK	Frequency	f_{CLK}	21	25	32	MHz	
	Width-Low	t_{WCL}	7	-	-	ns	
	Width-High	t_{WCH}	7	-	-		
	Rise Time	t_{rCLK}	-	-	20		
	Fall Time	t_{fCLK}	-	-	20		
	Duty	D	0.45	0.5	0.55		-
Hsync	Set up Time	t_{SH}	0	-	-	ns	
	Hold Time	t_{HH}	15	-	-		
	Period	t_{HP}	770	800	900		
	Width-Active	t_{WH}	9	-	128		
	Rise/Fall Time	t_{Hr}, t_{Hf}	-	-	30	ns	
Vsync	Set up Time	t_{SV}	0	-	-	t_{CLK}	for Hsync
	Hold Time	t_{HV}	15	-	-		
	Period	t_{VP}	515	525	560	t_{HP}	
	Width-Active	t_{WV}	1	-	15		
	Rise/Fall Time	t_{Vr}, t_{Vf}	-	-	50		
DTMG	Set up Time	t_{ST}	0	-	-	ns	for DCLK
	Hold Time	t_{HT}	15	-	-		
	Rise/Fall Time	t_{Ir}, t_{If}	-	-	30	ns	
	Horizontal Back Porch	t_{HBP}	10	-	-	t_{CLK}	
	Horizontal Front Porch	t_{HFP}	10	-	-		
	Vertical Back Porch	t_{VBP}	34	-	-	t_{HP}	
	Vertical Front Porch	t_{VFP}	1	-	-		

Product Specification

DATA	Set up Time	t_{SD}	0	-	-	ns	for DCLK
	Hold Time	t_{HD}	15	-	-		
	Rise/Fall Time	t_{Dr}, t_{Df}	-	-	20		

8. Signal Timing Wave form

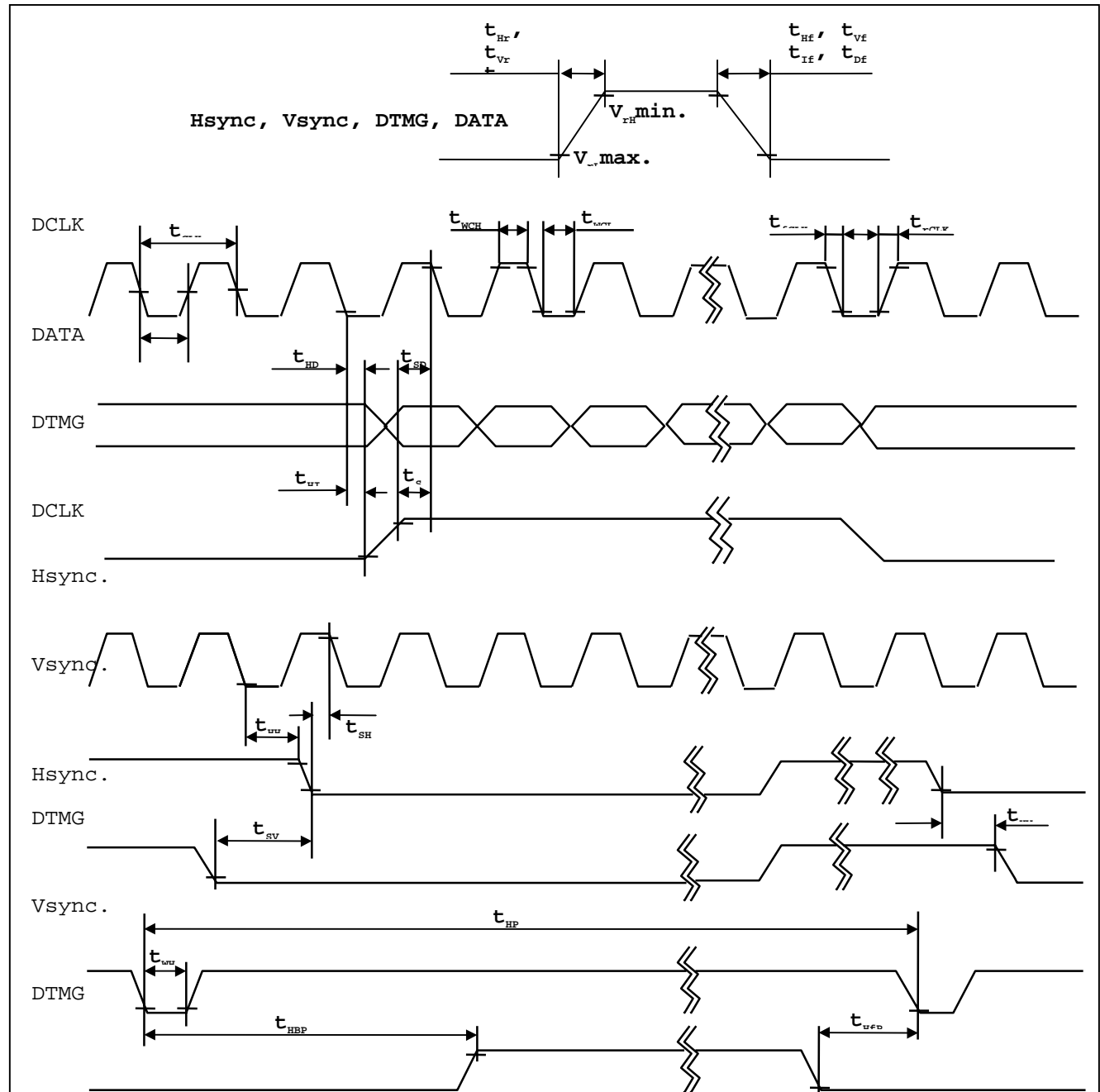

9. Color Input Data Reference

The brightness of each primary color (red, green and blue) is based on the 6-bit gray scale data input for the color; the higher the binary input, the brighter the color. The table below provides a reference for color versus data input.

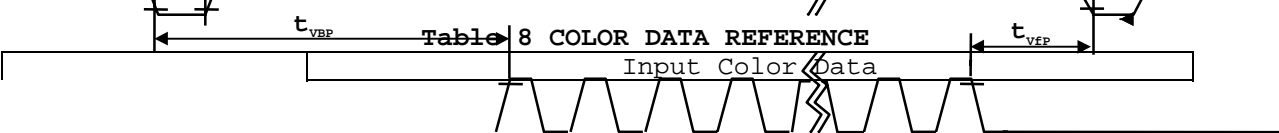

Product Specification

Color		Red						Green						Blue					
		MSB						MSB						MSB					
		LSB						LSB						LSB					
		R5	R4	R3	R2	R1	R0	G5	G4	G3	G2	G1	G0	B5	B4	B3	B2	B1	B0
Basic Colors	Black	0	0	0	0	0	0	0	0	0	0	0	0	0	0	0	0	0	0
	Red(63)	1	1	1	1	1	1	0	0	0	0	0	0	0	0	0	0	0	0
	Green(63)	0	0	0	0	0	0	1	1	1	1	1	1	0	0	0	0	0	0
	Blue(63)	0	0	0	0	0	0	0	0	0	0	0	0	1	1	1	1	1	1
	Cyan	0	0	0	0	0	0	1	1	1	1	1	1	1	1	1	1	1	1
	Magenta	1	1	1	1	1	1	0	0	0	0	0	0	0	1	1	1	1	1
	Yellow	1	1	1	1	1	1	1	1	1	1	1	1	0	0	0	0	0	0
	White	1	1	1	1	1	1	1	1	1	1	1	1	1	1	1	1	1	1
Red	Red(00) Dark	0	0	0	0	0	0	0	0	0	0	0	0	0	0	0	0	0	0
	Red(01)	0	0	0	0	0	1	0	0	0	0	0	0	0	0	0	0	0	0
	Red(02)	0	0	0	0	1	0	0	0	0	0	0	0	0	0	0	0	0	0
	:	:	:	:	:	:	:	:	:	:	:	:	:	:	:	:	:	:	:
	Red(61)	1	1	1	1	0	1	0	0	0	0	0	0	0	0	0	0	0	0
	Red(62)	1	1	1	1	1	0	0	0	0	0	0	0	0	0	0	0	0	0
	Red(63)	1	1	1	1	1	1	0	0	0	0	0	0	0	0	0	0	0	0
	Bright																		
Green	Green(00)Dark	0	0	0	0	0	0	0	0	0	0	0	0	0	0	0	0	0	0
	Green(01)	0	0	0	0	0	0	0	0	0	0	0	1	0	0	0	0	0	0
	Green(02)	0	0	0	0	0	0	0	0	0	0	1	0	0	0	0	0	0	0
	:	:	:	:	:	:	:	:	:	:	:	:	:	:	:	:	:	:	:
	Green(61)	0	0	0	0	0	0	1	1	1	1	0	1	0	0	0	0	0	0
	Green(62)	0	0	0	0	0	0	1	1	1	1	1	0	0	0	0	0	0	0
	Green(63)Bright	0	0	0	0	0	0	1	1	1	1	1	1	0	0	0	0	0	0
Blue	Blue(00) Dark	0	0	0	0	0	0	0	0	0	0	0	0	0	0	0	0	0	0
	Blue(01)	0	0	0	0	0	0	0	0	0	0	0	0	0	0	0	0	0	1
	Blue(02)	0	0	0	0	0	0	0	0	0	0	0	0	0	0	0	0	1	0
	:	:	:	:	:	:	:	:	:	:	:	:	:	:	:	:	:	:	:
	Blue(61)	0	0	0	0	0	0	0	0	0	0	0	0	1	1	1	1	0	1
	Blue(62)	0	0	0	0	0	0	0	0	0	0	0	0	1	1	1	1	1	0
	Blue(63)	0	0	0	0	0	0	0	0	0	0	0	0	1	1	1	1	1	1
	Bright																		

Product Specification

10. Power On/Off Sequence

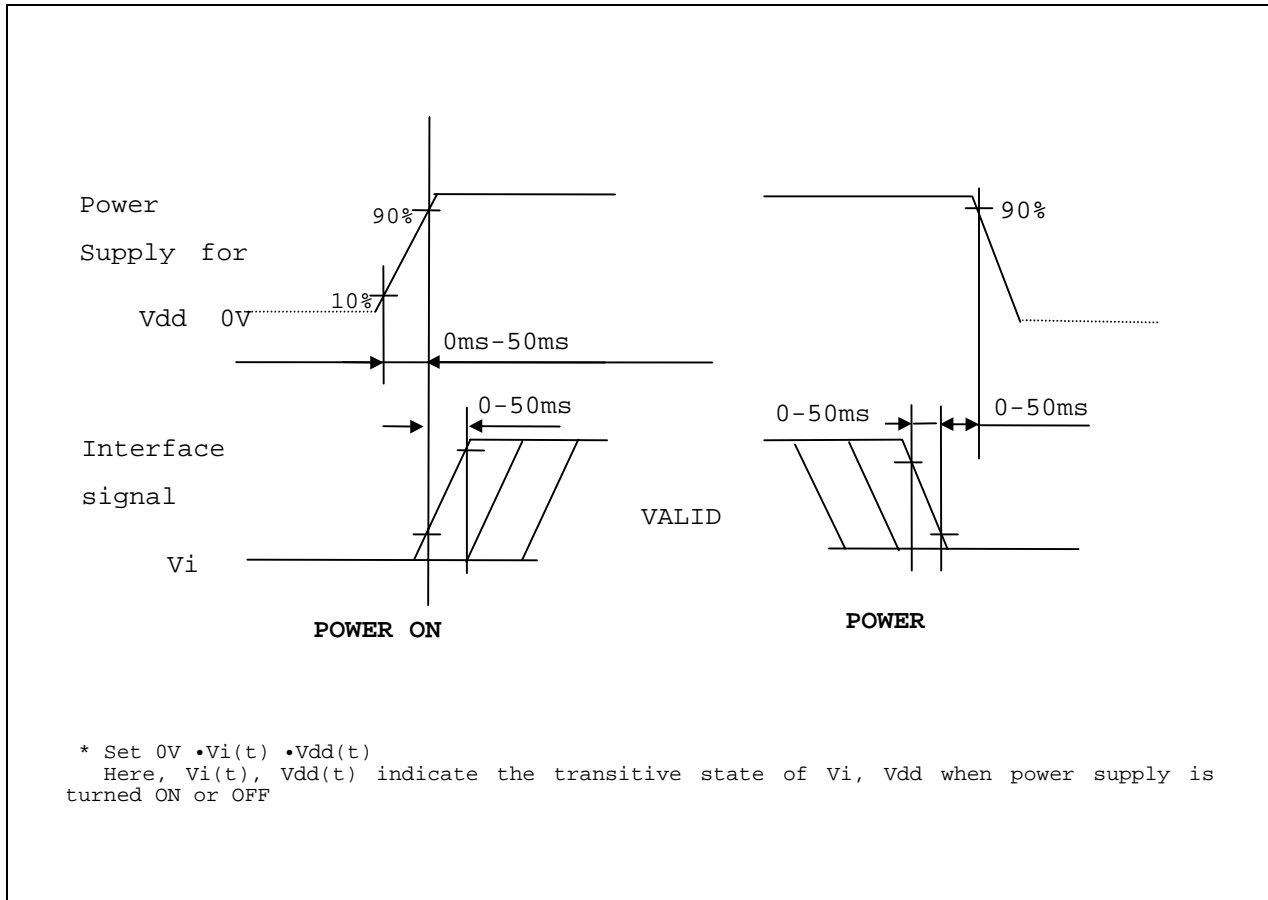

- Notes :
1. Please avoid floating state of interface signal at invalid period.
 2. When the interface signal is invalid, be sure to pull down the power supply for LCD V_{DD} to 0V.

Product Specification

12. COSMETICS

This cosmetic inspection is related to the acceptance quality levels of any defects in the LCD module which we produce.

For more information about the following , contact LG LCD Inc. any time.

12.1 Cosmetic Inspection Conditions

12.1.1 Inspective viewing angle

- This inspection should be executed according to the following figure.

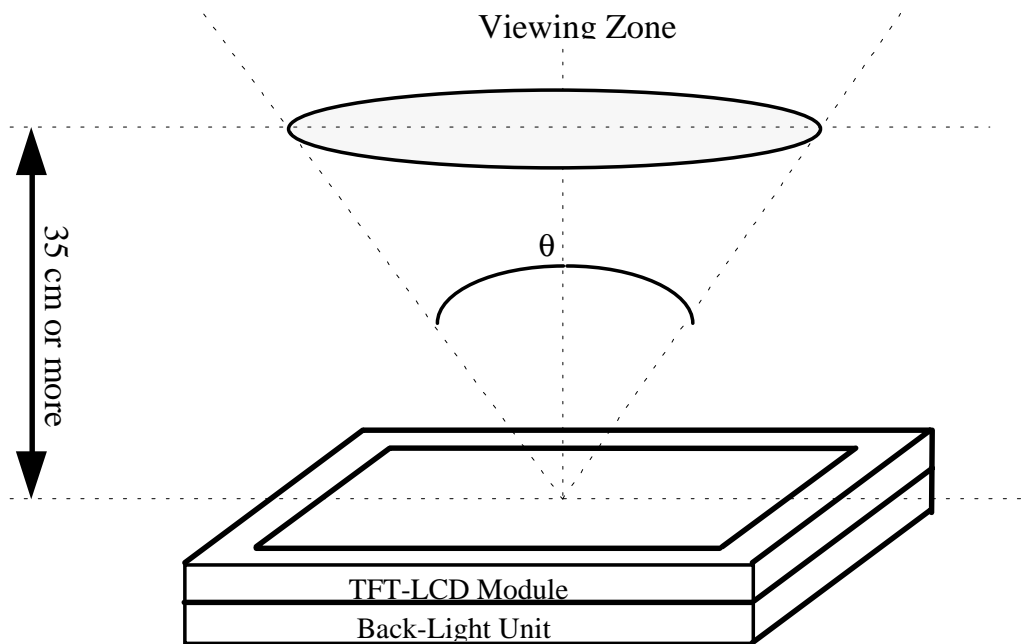

- Viewing angle should be in the range of :
 - $\alpha < 45^\circ$ when non-operating inspection
 - $\alpha < 20^\circ$ when operating inspection (Horizontal direction)
 - $\alpha < 10^\circ$ when operating inspection (Vertical direction)

12.1.2 Environment Conditions

- Ambient temperature : $25 \pm 5^\circ\text{C}$
- Ambient Humidity : $65 \pm 5\% \text{ RH}$
- Ambient Luminance : Using single 20 watts fluorescent lamp (about 500 lux)
- Distance by eyes of inspector from the module : 35 cm or more

Product Specification**13. Safety**

13.1 Sharp edge : There will be no sharp edges or corners on the display assembly that could cause injury.

13.2 materials

13.2.1 Toxicity :There is no carcinogenic materials used anywhere in the display module.

13.2.2 Flammability : All components including electrical components of the module should meet the flammability grade Min.UL94-V1. The printed circuit board is made from material rated UL94-V1 or better. The actual UL flammability rating is printed on the printed circuit board.

13.2.3 capacitors : If any polarized capacitors are used in the display assembly, provisions will be made to keep them from being inserted backwards.

13.2.4 Hazardous Voltages : Any points exceeding 42.2volts meets the requirement of the limited current circuit. The current through a 2 Kohm resistance is less than $0.7 \times f(\text{Khz})\text{mA}$.

14. Packaging

: The packaging of the LCD meets 75 cm drop test.

15. Smoke free design

: No smoke or strange smell shall not be observed by the operator as a result of any single failure.

Display technology will demonstrate it to the representative by open/short test in design verification test for approval if there is any default symptoms.

16. Performance

: All electromagnetic compatibility apply when the display module is attached to the host system.

Product Specification**17. PRECAUTIONS**

Please pay attention to the followings when you use this TFT/LCD module with Back-light unit.

17.1 MOUNTING PRECAUTIONS

- (1) You must mount a module using holes arranged in four corners.
- (2) You should consider the mounting structure so that uneven force (ex. twisted stress) is not applied to the module.
And the case on which a module is mounted should have sufficient strength so that external force is not transmitted directly to the module.
- (3) Please attach the surface with a transparent protective plate in order to protect the polarizer LC cell.
Transparent protective plate should have sufficient strength in order to resist external force.
- (4) You should adopt radiation structure to satisfy the temperature specification.
- (5) Acetic acid type and chlorine type materials for the cover case are not desirable because the former generates corrosive gas of attacking the polarizer at high temperature and the latter causes circuit break by electro-chemical reaction.
- (6) Do not touch, push or rub the exposed polarizers with glass, tweezers or anything harder than HB pencil head.
And Please do not rub with dust clothes with chemical treatment.
Do not touch the surface of polarizer for bare hand or greasy cloth.
(Some cosmetics are detrimental to the polarizer.)
- (7) When the surface becomes dusty, please wipe gently with absorbent cotton or other soft materials like chamois soaked with petroleum benzene. Normal-hexane is recommended for cleaning the adhesives used to attach front / rear polarizers. Do not use acetone, toluene and alcohol because they cause chemical damage to the polarizer.
- (8) Wipe off saliva or water drops as soon as possible. Their long time contact with polarizer causes deformations and color fading.
- (9) Do not open the case because inside circuits do not have sufficient strength.

17.2 OPERATING PRECAUTIONS

- (1) The spike noise causes the mis-operation of circuits. It should be lower than following voltage :
 $V_{DD} = \pm 200\text{mV}$, $V_1 = \pm 200\text{mV}$ (Over and under shoot voltage).
- (2) Response time depends on the temperature. (In lower temperature, it becomes longer.)
- (3) Brightness depends on the temperature. (In lower temperature, it becomes lower.)
And in lower temperature, response time (required time that brightness is stable after turned on) becomes longer.
- (4) Be careful for condensation at sudden temperature change. Condensation makes damage to polarizer or electrical contacted parts. And after fading condensation, smear or spot will occur.
- (5) When fixed patterns are displayed for a long time, remnant image is

Product Specification

likely to occur.

(6) A module has high frequency circuit. If you need to shield the electromagnetic noise,

please do in yours.

(7) When a Back-light unit is operating, it sounds. If you need to shield the noise,

please do in yours.

17.3 ELECTROSTATIC DISCHARGE CONTROL

Since a module is composed of electronic circuits, it is not strong to electrostatic discharge. Make certain that treatment persons are connected to ground through wrist band etc . . And don't touch I/F pin directly.

17.4 PRECAUTION FOR STRONG LIGHT EXPOSURE

Strong light exposure causes degradation of polarizer and color filter.

17.5 STORAGE

When storing modules as spares for a long time. The following precautions are necessary.

(1) Do not leave the module in high temperature, especially in high humidity for a long time.

(2) Store the module not to expose to the sunlight directly.

(3) Avoid condensation of water. It may cause mis-operation.

17.6 HANDLING PRECAUTIONS FOR PROTECTION FILM

(1) Be sure to turn off the power when connecting or disconnecting circuit.

(2) Note that polarizer are easily damaged, pay attention not to scratch or press these surface with any hard object.

(3) When LCD surface become dirty, please wipe them off with soft material like absorbent cotton.

(4) Protect the module from the ESD. AS it may damage electronic circuit (C-MOS)

Make certain that treatment persons body are grounded through wrist bend.

(5) Do not disassemble the module and be careful not to have strong mechanical shock such

as twist when install to the cabinet. It may cause damage permanently.

Product Specification

< APPENDIX >

A-1 Measurement setup & method

Optical measurement shall be executed in a dark room or equivalent state with the following method.
Measurement shall be executed 30 minutes after back light turn on.

OPTICAL STAGE (X,Y)

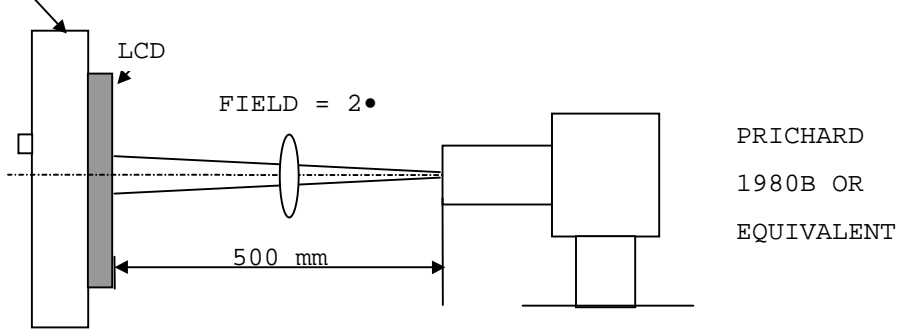

A-2 Brightness

<measuring point for brightness variation>
<brightness >

<measuring point for surface brightness >

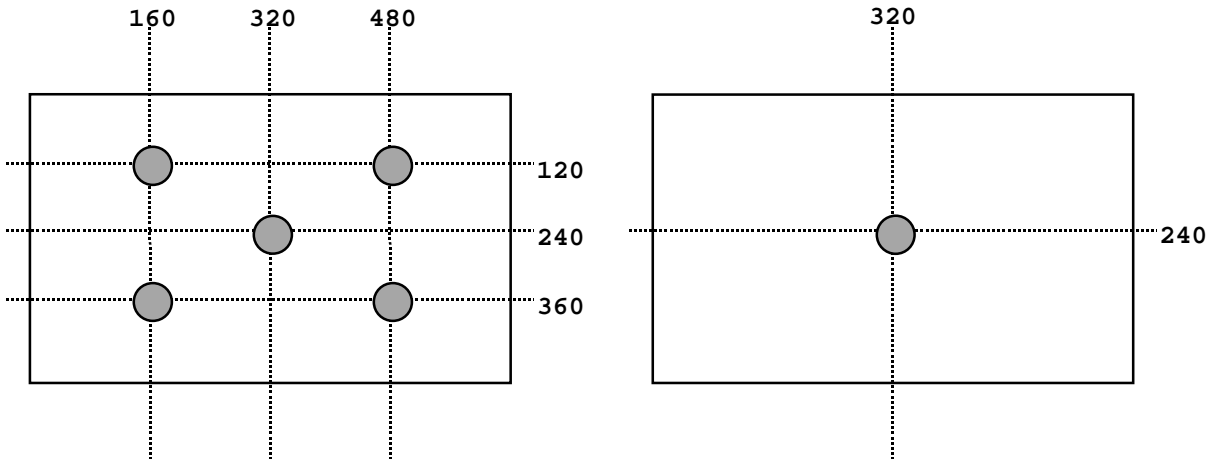

A-3 RESPONSE TIME

The response time is defined as the following figure and shall be measured by switching the input signal for “black” and “white”.

Product Specification

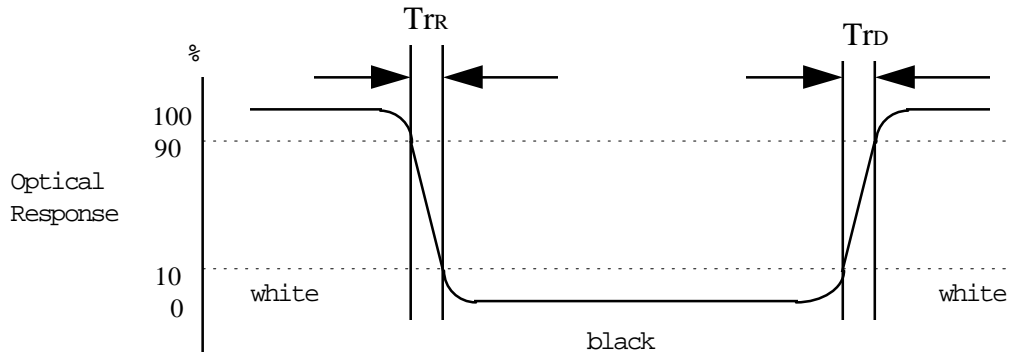

A-4 Viewing angle

<Definition of viewing angle range>

