

# **DM5952HR/DM6952HR**

## **Power relay output module**

### **User's Manual**

**Hardware Revision 1.0 – 1.1**

---

---

**DM5952HR/DM6952HR**  
**POWER RELAY OUTPUT MODULE**  
**User's Manual**

---

---

**REAL TIME DEVICES FINLAND OY**  
LEPOLANTIE 14  
FIN-00660 HELSINKI  
FINLAND

Phone: (+358) 9 346 4538  
FAX: (+358) 9 346 4539

E-Mail  
sales@rtdfinland.fi

Website  
www.rtdfinland.fi

Revision History

03/09/1999	Release 1.0
13/07/2001	Name of company changed, formatted pages

**IMPORTANT**

**Although the information contained herein has been carefully verified RTD Finland Oy assumes no responsibility for any errors that may occur, for any damage to property or persons resulting from improper use of this manual or from the related software. RTD Finland Oy also reserves the right to alter the contents of this manual, as well as features and specifications of this product at any time, without prior notice.**

**Notice:** We have attempted to verify all information in this manual as of the publication date. Information in this manual may change without prior notice from RTD Finland Oy.

Published by  
Real Time Devices Finland Oy  
Lepolantie 14  
FIN-00660 Helsinki  
Finland

Copyright 1999-2000 Real Time Devices Finland Oy  
All rights reserved  
Printed in Finland

PC/XT, PC/AT are registered trademarks of IBM Corporation.  
PC/104 is a registered trademark of PC/104 Consortium.  
The Real Time Devices Logo is a registered trademark of Real Time Devices.  
utilityModule is a trademark of Real Time Devices.  
All other trademarks appearing in this document are the property of their respective owners

## TABLE OF CONTENTS

<b>LIST OF ILLUSTRATIONS &amp; TABLES</b> .....	5
<b>CHAPTER 1 - INTRODUCTION</b> .....	6
Features.....	6
Power relays.....	6
Mechanical description.....	6
Connector description.....	6
What comes with your board.....	7
Board accessories.....	7
-Application software and drivers	
-Hardware accessories	
Using this manual.....	7
When you need help.....	7
<b>CHAPTER 2 - BOARD SETTINGS</b> .....	8
Factory-Configured Jumper Settings.....	9
Base Address Jumpers.....	9
<b>CHAPTER 3 - BOARD INSTALLATION</b> .....	11
Board installation.....	11
External I/O connections.....	13
<b>CHAPTER 4 - HARDWARE DESCRIPTION</b> .....	15
Relay outputs.....	16
Rese.....	16
Fuses.....	16
<b>CHAPTER 5 - BOARD OPERATION AND PROGRAMMING</b> ...17	
Defining the I/O map.....	17
-Base+0           I/O register 1	
-Base+1           I/O register 2	
Programming the DM5952HR/DM6952HR.....	18
Clearing and setting bits in a port.....	18
Output programming.....	19
<b>CHAPTER 6 - DM5952HR/DM6952HR SPECIFICATIONS</b> .....20	
<b>CHAPTER 7 - RETURN POLICY &amp; WARRANTY</b> .....21	

## List of Illustrations & Tables

### Illustrations

- Fig. 2-1: Board layout showing jumper locations
- Fig. 2-2: Base address jumpers (factory default)
- Fig. 3-1: DM6952HR integrated in a PC/104 dataModule stack
- Fig. 3-2: 19" Eurocard rack installation with an integrated PC/104 data Module and EUROCARD cpuModule computer system
- Fig. 4-1: DM5952HR/DM6952HR Block diagram
- Fig. 4-2: The relay output connection diagram

### Tables

- Table 2.1: Factory Jumper settings
- Table 2.2: Base Address jumper settings
- Table 3.1: The output connector pin outs
- Table 5.1: DM5952HR/DM6952HR I/O - map

## Chapter 1 INTRODUCTION

This User's Manual describes the operation and characteristics of the DM5952HR/DM6952HR power relay output board.

### **Features**

**Some of the key features of the DM5952HR/DM6952HR include:**

- 16 power relay outputs
- 60 VA switching capability from DC to 230 VAC
- Operate and release time only 4 ms
- Max load 30 VDC / 2 A or 125 VAC / 0.5 A
- 500 VAC or DC isolation from PC
- RTD IDAN compatible
- XT (DM5952HR) and AT (DM6952HR) boards available
- +5V only operation
- Fully PC/104 compliant

The following paragraphs briefly describe the major features of the DM5952HR and DM6952HR. A more detailed discussion is included in Chapter 3 (Hardware description), and in Chapter 4 (Board operation and programming). The board set-up is described in Chapter 1 (Board Settings).

### **Power relays**

16 relay outputs may be used to directly drive loads that need high current such as solenoids, lamps or motors. Reliability relays lifetime reached 100 million operations. Short action time 4 ms operate and release, ensure reliable high speed switching. Each relay has 3 contacts, Normally Open, Common and Normally closed. The contact arrangement is parallel- connected DPCO.

### **Mechanical description**

The DM5952HR is designed on a PC/104 form factor. An easy mechanical interface to both PC/104 and EUROCARD systems can be achieved. Stack your PC/104 compatible computer directly on the DM5952HR using the onboard mounting holes.

### **Connector description**

There are either two 50 pin interface connectors or two 25 position screw terminal blocks on the DM5952HR/DM6952HR board. The connector style is indicated with following order codes:

DM6952HR-H	Header connectors
DM6952HR-S	Screw terminal blocks

## ***What comes with your board***

Your DM5952HR/DM6952HR package contains the following items:

- DM5952HR/DM6952HR Power relay module
- User's manual

Note: WIN95/98/2000/NT4.0 drivers and diagnostics software is available free of charge on our website [www.rtdfinland.fi](http://www.rtdfinland.fi)

If any item is missing or damaged, please call Real Time Devices Finland customer service department at the following number: (+358) 9 346 4538.

## ***Board accessories***

In addition to the items included in your DM5952HR/6952 delivery, several software and hardware accessories are available. Contact your distributor for more information and for advice on selecting the most appropriate accessories to support your instrumentation system.

- **Application software and drivers**
- **Hardware accessories**

Real Time Devices can supply a complete set of accessories for your DM5952HR/DM6952HR card. These include Eurocard enclosures and power supplies, terminal boards (TB50), and other connection systems. The board is also available in the rugged IDAN enclosure system. Please consult the factory for more details or visit our website at [www.rtdfinland.fi](http://www.rtdfinland.fi) or [www.rtdusa.com](http://www.rtdusa.com).

## ***Using this manual***

This manual is intended to help you install your new board and get it working quickly, while also providing enough detail about the board and its functions so that you can enjoy maximum use of its features even in the most demanding applications.

## ***When you need help***

This manual and all the example programs will provide you with enough information to fully utilize all the features on this board. If you have any problems with installation or use of the board, contact our Technical Support Department (+358) 9 346 4538 during European business hours. Alternatively, send a FAX to (+358) 9 346 4539, or Email to: [sales@rtdfinland.fi](mailto:sales@rtdfinland.fi). When sending a FAX or Email request please include the following information: Your company's name and address, your name, your telephone number, and a brief description of the problem.

## Chapter 2 BOARD SETTINGS

The DM5952HR/DM6952HR Power Relay board has jumper settings that can be changed to suit your application. The factory settings are listed and shown in the diagram in the beginning of this chapter.

### Factory-Configured Jumper Settings

Table 2-1 below illustrates the factory jumper setting for the DM5952HR and DM6952HR. It also shows the board layout of the board and the locations of the jumpers. The following paragraphs explain how to change the factory jumper settings to suit your specific application.

Table 2-1: Factory jumper settings (see figure 2-1 below for detailed locations)

Jumper name	Jumper description	Number of Jumpers	Factory setting jumpers installed
Base address	Base address	8	300h

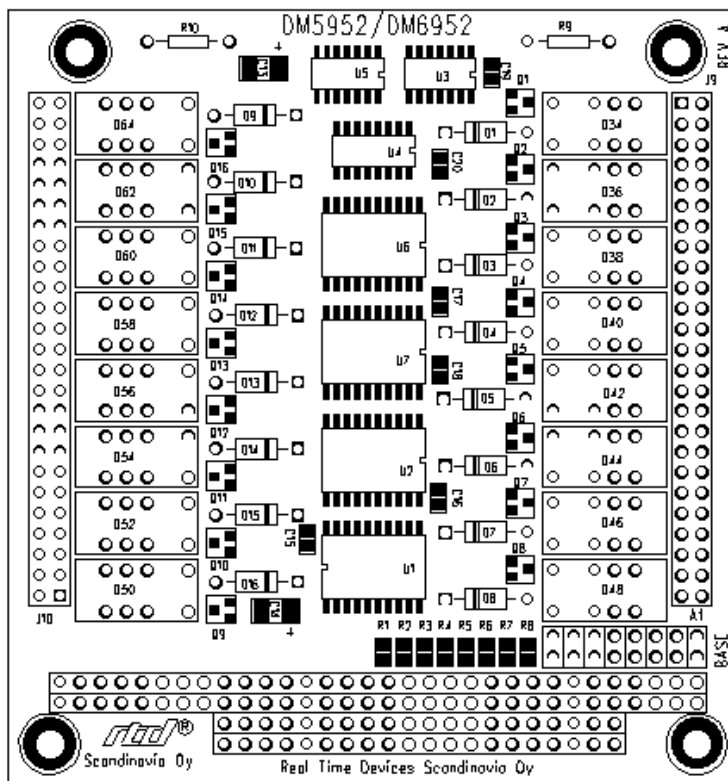

Figure 2-1 - Board layout showing jumper locations (Figure shows DM6952HR board)

## Base address Jumpers (Factory setting: 300h)

The most common cause of failure when you are first setting up your module is address contention. Some of your computer's I/O-space is already occupied by other internal I/O devices and expansion boards. When the board attempts to use its own reserved I/O addresses (which are being already used by another peripheral device), erratic performance may occur and the data read from the board may be corrupted.

To avoid this problem make sure you set up the base address first using the eight jumpers marked "BASE". It allows you to choose from 256 different I/O addresses in your computer I/O map. Should the factory installed setting of 300h be unusable for your system configuration, you may change this setting to another using the options illustrated in Table 2-2 (below). The table shows the switch settings and their corresponding values in hexadecimal values. Ensure that you verify the correct location of the base address jumpers. When the jumper is removed it corresponds to a logical "0", connecting the jumper to a "1". When you set the base address of the module, record the setting inside the back cover of this manual (directly after the Appendices).

### BASE ADDRESS JUMPER SETTINGS FOR DM5952HR/DM6952HR BOARDS

Base address Hex / (Decimal)	Jumper Settings 8 7 6 5 4 3 2 1	Base Address Hex / (Decimal)	Jumper settings 8 7 6 5 4 3 2 1
200 / (512)	0 0 0 0 0	300 / (768)	1 0 0 0 0
210 / (528)	0 0 0 0 1	310 / (784)	1 0 0 0 1
220 / (544)	0 0 0 1 0	320 / (800)	1 0 0 1 0
230 / (560)	0 0 0 1 1	330 / (816)	1 0 0 1 1
240 / (576)	0 0 1 0 0	340 / (832)	1 0 1 0 0
250 / (592)	0 0 1 0 1	350 / (848)	1 0 1 0 1
260 / (608)	0 0 1 1 0	360 / (864)	1 0 1 1 0
270 / (624)	0 0 1 1 1	370 / (880)	1 0 1 1 1
280 / (640)	0 1 0 0 0	380 / (896)	1 1 0 0 0
290 / (656)	0 1 0 0 1	390 / (912)	1 1 0 0 1
2A0 / (672)	0 1 0 1 0	3A0 / (928)	1 1 0 1 0
2B0 / (688)	0 1 0 1 1	3B0 / (944)	1 1 0 1 1
2C0 / (704)	0 1 1 0 0	3C0 / (960)	1 1 1 0 0
2D0 / (720)	0 1 1 0 1	3D0 / (976)	1 1 1 0 1
2E0 / (736)	0 1 1 1 0	3E0 / (992)	1 1 1 1 0
2F0 / (752)	0 1 1 1 1	3F0 / (1008)	1 1 1 1 1

**1 = NOT JUMPERED, 0 = JUMPER INSTALLED**

Table 2-2: Base Address Jumper settings, factory default Base Address shaded

Note: In the table above only the MSB address decoder jumper settings are illustrated. You may also connect jumpers 1-3 to decode address A1-A3

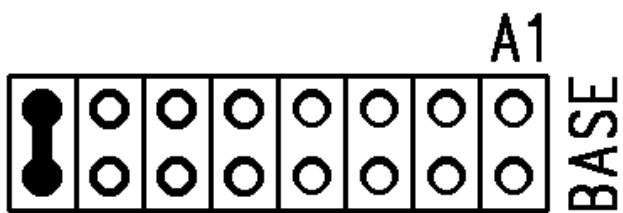

Figure 2-2 Base Address jumpers set for 300H.

## Chapter 3 INSTALLATION

The DM5952HR/DM6952HR Power relay board is very easy to connect to your industrial or automotive control system. Direct interface to PC/104 systems as well as EUROCARD boards is possible. This chapter gives step-by-step instructions on how to install the board into your system.

After completing the installation it is recommended that you use the diagnostic software to fully verify that your board is working.

### Board Installation

Keep your board in the antistatic bag until you are ready to install it to your system! When removing it from the bag, hold the board at the edges and do not touch the components or connectors. Please handle the board in an antistatic environment and use a **grounded** workbench for testing and handling of your hardware. Before installing the board in your computer, check the jumper settings. Chapter 1 reviews the factory settings and how to alter them. If any alterations are needed, please refer to the appropriate instructions in this chapter. Do however note that incompatible settings can result in unpredictable board operation and erratic response.

#### General installation guidelines:

- Turn OFF the power to your computer
- Touch the grounded metal housing of your computer to discharge any antistatic build-up and then remove the board from its antistatic bag.
- Hold the board by the edges and install it in an enclosure or place it on the table on an antistatic surface.

Connect the board to the I/O devices using the twisted pair 50-pin flat cable or discrete wires.

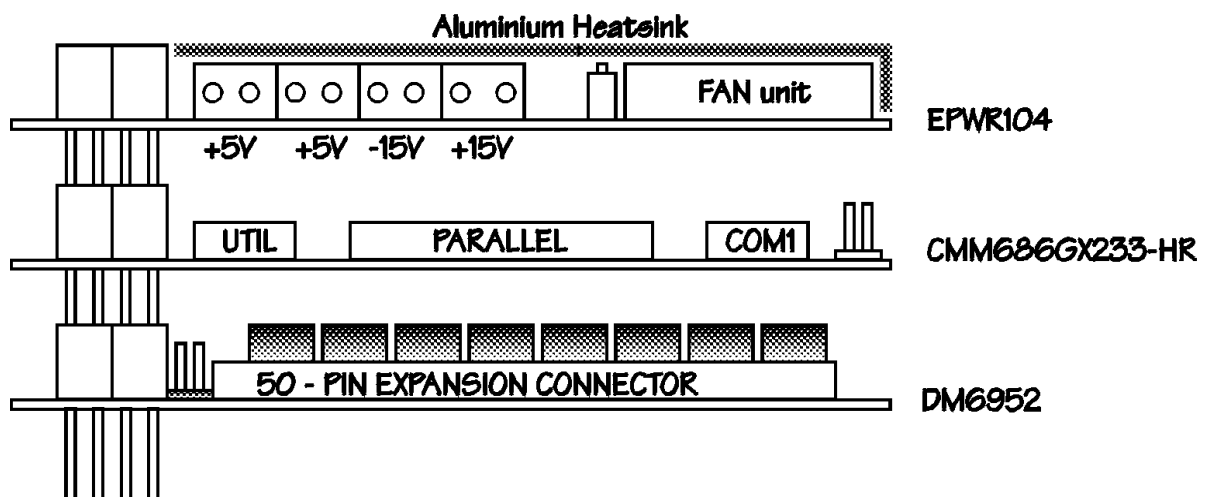

Fig. 3-1: DM6952HR integrated in a PC/104 RTD cpuModule stack

### 3U rack or enclosure installation with a EUROCARD CPU with one DM6952HR

The PC/104 system can easily be inserted into a 19" rack installation using the CPU as a "form factor adapter". Assemble your PC/104 data modules on a RTD single board EUROCARD computer and install the system in a 19" enclosure. Multiple DM6952HR boards can be easily connected to this system. See figure 3-2 below.

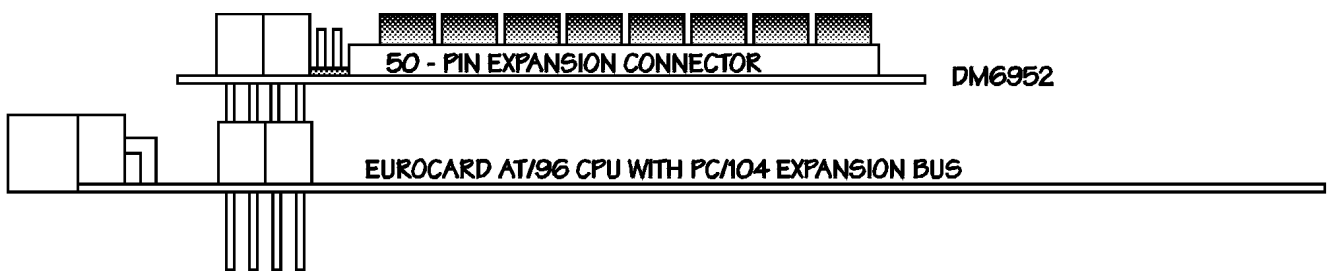

Fig 3-2: 19" Eurocard rack installation with an integrated PC/104 dataModule and EUROCARD cpuModule computer system

## External I/O Connections

Table 3-1 below shows the **output** connection pin outs

**J9 (right side, top view, pin#1 away from bus)**

**J10 (left side, top view, pin#1 toward bus)**

Connection	Pin	Pin	Connection
0 NO	1	2	0 NO
0 C	3	4	0 C
0 NC	5	6	0 NC
1 NO	7	8	1 NO
1 C	9	10	1 C
1 NC	11	12	1 NC
2 NO	13	14	2 NO
2 C	15	16	2 C
2 NC	17	18	2 NC
3 NO	19	20	3 NO
3 C	21	22	3 C
3 NC	23	24	3 NC
4 NO	25	26	4 NO
4 C	27	28	4 C
4 NC	29	30	4 NC
5 NO	31	32	5 NO
5 C	33	34	5 C
5 NC	35	36	5 NC
6 NO	37	38	6 NO
6 C	39	40	6 C
6 NC	41	42	6 NC
7 NO	43	44	7 NO
7 C	45	46	7 C
7 NC	47	48	7 NC
Not used	49	50	Not used

Connection	Pin	Pin	Connection
8 NO	1	2	8 NO
8 C	3	4	8 C
8 NC	5	6	8 NC
9 NO	7	8	9 NO
9 C	9	10	9 C
9 NC	11	12	9 NC
10 NO	13	14	10 NO
10 C	15	16	10 C
10 NC	17	18	10 NC
11 NO	19	20	11 NO
11 C	21	22	11 C
11 NC	23	24	11 NC
12 NO	25	26	12 NO
12 C	27	28	12 C
12 NC	29	30	12 NC
13 NO	31	32	13 NO
13 C	33	34	13 C
13 NC	35	36	13 NC
14 NO	37	38	14 NO
14 C	39	40	14 C
14 NC	41	42	14 NC
15 NO	43	44	15 NO
15 C	45	46	15 C
15 NC	47	48	15 NC
Not used	49	50	Not used

<b>Signal</b>	<b>Definition</b>
<b>NO</b>	“Normally Open” contact, when power is off or a 0 bit is written to the relay control register, this contact is not connected. When power is on and a 1 bit is written to the relay control register this signal is connected to the C (common) contact.
<b>C</b>	Relay common contact; this contact is always used with relay output connections.
<b>NC</b>	“Normally closed” contact, when power is off or a 0 bit is written to the relay control register this contact is connected to the C (common) contact. When power is on and a 1 bit is written to the relay control register this contact is not connected.

---

Note: When using header connector such as on the DM5952HR-H board all the pins are used, but on the DM5952HR-S boards the even pins are used since the connector is a single row screw terminal with 25 contacts.

---

## Chapter 4 - HARDWARE DESCRIPTION

This chapter describes in detail the features of the DM5952HR/DM6952HR board

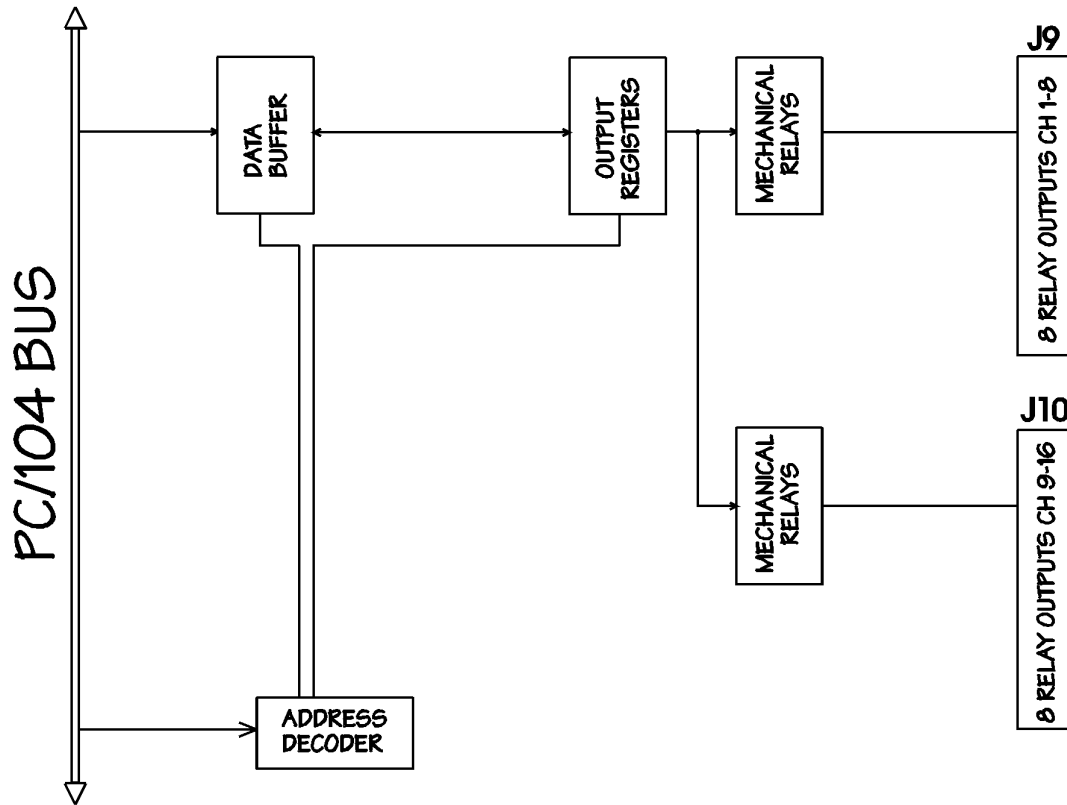

Fig 4-1: DM5952HR/DM6952HR Block diagram

## Relay outputs

The DM5952HR/6952 features 16 onboard miniature relays designed to switch up to 2A of current. These devices may be connected either with Normally open or Normally closed poles. Both options are available on the expansion connectors. Directly wire your I/O signals to your board onto the screw terminal connectors of the DM6952HR-S module or use flat ribbon cables to interface to your DM6952HR-H module. Figure 4-1 below illustrates the connection of the relays used on your DM6952HR. Also please refer to the wiring table in the previous chapter when making connections. More information about the relays used you will find at the address: [http://www.mac-europe.com/downloads/relay\\_pdf/TXE.PDF](http://www.mac-europe.com/downloads/relay_pdf/TXE.PDF).

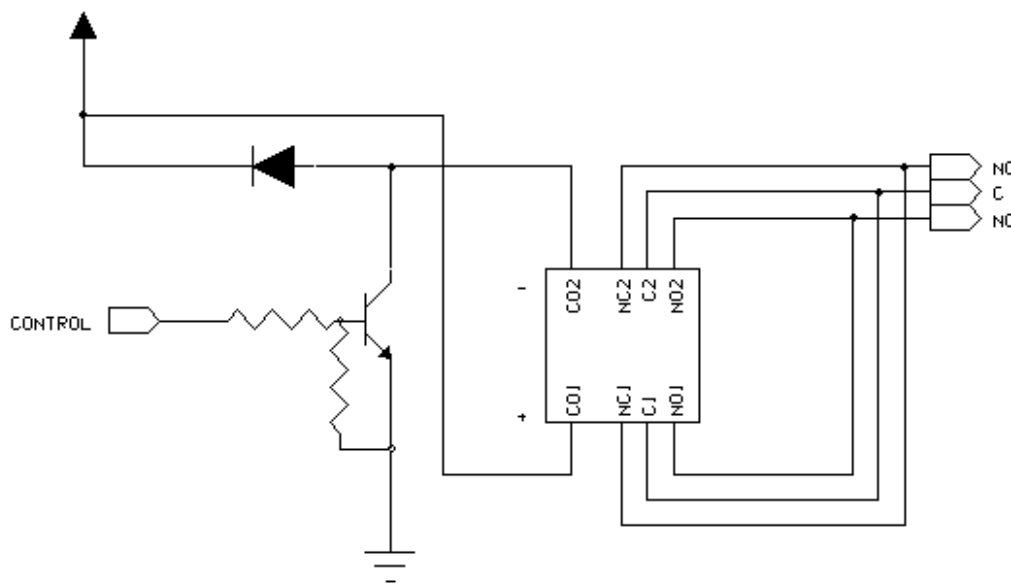

Fig 4-2: This diagram illustrates the output relay connection

## Resets

On circuitry only enables one reset that clears the outputs. This is the first reset occurring at power-up. The state of the relay outputs does not change even though a system software or hardware reset (WDT) may occur. Only a software-write to the output register will update state of the relay outputs.

## Fuses

The DM5952HR/DM6952HR Power relay board is protected against over loading or error conditions in the relay coils with two fuses. These fuses protect a group of 8 relays. The fuses are located to the top of your board (away from the bus connector). The fuse type is 2A quick blow.

## Chapter 5 - BOARD OPERATION AND PROGRAMMING

This chapter shows you how to program and use your DM5952HR/DM6952HR: It provides a complete description of the I/O-map plus a detailed discussion of programming operations to aid you in programming.

### *Defining the I/O Map*

The I/O map of the DM5952HR/DM6952HR is shown in Table 5-1 below. As shown, the module occupies two addresses. The Base Address (designated as BA) can be set using the jumpers as described in Chapter 2 (Board settings). The following sections describe the register contents of each address used in the I/O map.

**Table 5-1: DM5952HR/DM6952HR I/O Map**

Register Description	Write Function	Address in HEX
Low Byte (ch. 1-8)	Relay outputs 1-8	BA+0
High Byte (ch. 9-16)	Relay outputs 9-16	BA+1

BA = Base Address

### **BA+0 Digital Outputs**

The Data Output register controls the output relays 1-8. Data is transferred from the Data register to the outputs by performing an 8-bit write to **BA+0**. Direct transfer of data to the output latch for all the 16 bits can be performed by executing a 16-bit write to BA+0. The address decoder of the DM5952HR will automatically write consecutive addresses BA+0 and BA+1 with the correct output data bytes.

### **BA+1 Digital Outputs**

This Data Output register controls the output relays 9-16. Data is transferred from the Data register to the outputs by performing an 8-bit write to **BA+1**.

## Programming the DM5952HR/DM6952HR

This section gives you some general information about programming the DM5952HR board. It then walks you through the major programming functions of the DM5952HR. This will help you use the example program that is included with the board. All of the program descriptions use decimal values unless otherwise specified.

The DM5952HR is programmed by writing data to the correct I/O-port addresses of the board. These I/O ports were described in the previous section 1 of this chapter. The following example shows how to perform a 8-bit write I/O port addresses using "C"-syntax and assembly code:

<b>Write:</b>	
<b>"C"-syntax</b>	<b>outp</b> (address,data);
<b>Assembly</b>	<b>mov</b> dx,address <b>mov</b> ax,data <b>out</b> dx,ax

### Clearing and setting bits in an I/O port

When you clear or set bits in an I/O port you must be careful not to alter the status of other bits. You can preserve the status of all the bits you do not wish to change by proper use of the bit-wise AND- and OR- operators. Using and /or operators, single or multiple bits can easily be set or cleared in one-line operations.

1. *To clear a single bit in a port*, AND the current value of the port with the value "B", where  $B = 255 - 2^{(\text{exp})}$  bit.
2. *To set a single bit in a port*, OR the current value of the port with the value "B", where  $B = 2^{(\text{exp})}$  bit.

Bits are numbered from 0-7 for the low byte of a word and from 8-15 for the high byte of a word. Setting and clearing of multiple bits in a byte or word is more complex.

3. *To clear multiple bits in a port*, AND the current value of the port with the value "B", where  $B = 255 -$  (the sum of the values of the bits to be cleared). Note that the bits do not have to be consecutive.
4. *To set multiple bits in a port*, OR the current value of the port with the value "B", where  $B =$  (sum of the individual bits to be set).

## ***Output Programming***

The relay outputs are controlled with a register structure. These outputs can be commanded in the following ways (examples in "C" syntax):

**1.**     *Software controlled byte write*

```
outp(BA,low_byte);  
outp(BA,high_byte);
```

**2.**     *Software controlled direct word write*

```
outpw(BA,word);
```

---

## Chapter 6 - DM5952HR/DM6952HR SPECIFICATIONS

---

### ***Host Interface***

Jumper selectable base address, I/O mapped

### ***Relay Outputs***

Number of lines	16 relays
Breakdown voltage	1000 V Rms
Max switching power (resistive load)	60 W
(motor load)	30 W
Max switching voltage	230 V DC
Max switching current	2 A
Nominal switching capacity	2 A, 30 V DC
Contact resistance	100 mOhms max

### ***Connectors***

Outputs	50 pin header or screw terminals
Bus connector	PC/104 XT or AT-bus

### ***Power requirements***

Supply voltage	+5V +/- 8%
	Supply current TBD

### ***Operating temperature range***

Standard	-40 to +85 C
----------	--------------

---

## Chapter 7 RETURN POLICY AND WARRANTY

---

### ***Return Policy***

If the module requires repair, you may return it to us by following the procedure listed below:

---

**Caution:** Failure to follow this return procedure will *almost always* delay repair! Please help us expedite your repair by following this procedure.

---

- 1) Read the limited warranty, which follows.
- 2) Contact the factory and request a Returned Merchandise Authorization (RMA) number.
- 3) On a sheet of paper, write the name, phone number, and fax number of a technically competent person who can answer questions about the problem.
- 4) On the paper, write a detailed description of the problem with the product. Answer the following questions:
  - Did the product ever work in your application?
  - What other devices were connected to the product?
  - How was power supplied to the product?
  - What features did and did not work?
  - What was being done when the product failed?
  - What were environmental conditions when the product failed?
- 5) Indicate the method we should use to ship the product back to you.
  - We will return warranty repairs by UPS Ground at our expense.
  - Warranty repairs may be returned by a faster service at your expense.
  - Non-warranty repairs will be returned by UPS Ground or the method you select, and will be billed to you.
- 6) Clearly specify the address to which we should return the product when repaired.
- 7) Enclose the paper with the product being returned.
- 8) Carefully package the product to be returned *using anti-static packaging!* We will not be responsible for products damaged in transit for repair.
- 7) Write the RMA number on the outside of the package.
- 8) Ship the package to:

Real Time Devices Finland Oy

Lepolantie 14

FIN-00660 Helsinki

FINLAND

## ***Limited Warranty***

Real Time Devices warrants the hardware and software products it manufactures and produces to be free from defects in materials and workmanship for one year following the date of shipment from REAL TIME DEVICES. This warranty is limited to the original purchaser of product and is not transferable.

During the one year warranty period, REAL TIME DEVICES will repair or replace, at its option, any defective products or parts at no additional charge, provided that the product is returned, shipping prepaid, to REAL TIME DEVICES. All replaced parts and products become the property of REAL TIME DEVICES. Before returning any product for repair, customers are required to contact the factory for an RMA number.

THIS LIMITED WARRANTY DOES NOT EXTEND TO ANY PRODUCTS WHICH HAVE BEEN DAMAGED AS A RESULT OF ACCIDENT, MISUSE, ABUSE (such as: use of incorrect input voltages, improper or insufficient ventilation, failure to follow the operating instructions that are provided by REAL TIME DEVICES, "acts of God" or other contingencies beyond the control of REAL TIME DEVICES), OR AS A RESULT OF SERVICE OR MODIFICATION BY ANYONE OTHER THAN REAL TIME DEVICES. EXCEPT AS EXPRESSLY SET FORTH ABOVE, NO OTHER WARRANTIES ARE EXPRESSED OR IMPLIED, INCLUDING, BUT NOT LIMITED TO, ANY IMPLIED WARRANTIES OF MERCHANTABILITY AND FITNESS FOR A PARTICULAR PURPOSE, AND REAL TIME DEVICES EXPRESSLY DISCLAIMS ALL WARRANTIES NOT STATED HEREIN. ALL IMPLIED WARRANTIES, INCLUDING IMPLIED WARRANTIES FOR MERCHANTABILITY AND FITNESS FOR A PARTICULAR PURPOSE, ARE LIMITED TO THE DURATION OF THIS WARRANTY. IN THE EVENT THE PRODUCT IS NOT FREE FROM DEFECTS AS WARRANTED ABOVE, THE PURCHASER'S SOLE REMEDY SHALL BE REPAIR OR REPLACEMENT AS PROVIDED ABOVE. UNDER NO CIRCUMSTANCES WILL REAL TIME DEVICES BE LIABLE TO THE PURCHASER OR ANY USER FOR ANY DAMAGES, INCLUDING ANY INCIDENTAL OR CONSEQUENTIAL DAMAGES, EXPENSES, LOST PROFITS, LOST SAVINGS, OR OTHER DAMAGES ARISING OUT OF THE USE OR INABILITY TO USE THE PRODUCT.

SOME STATES DO NOT ALLOW THE EXCLUSION OR LIMITATION OF INCIDENTAL OR CONSEQUENTIAL DAMAGES FOR CONSUMER PRODUCTS, AND SOME STATES DO NOT ALLOW LIMITATIONS ON HOW LONG AN IMPLIED WARRANTY LASTS, SO THE ABOVE LIMITATIONS OR EXCLUSIONS MAY NOT APPLY TO YOU.

THIS WARRANTY GIVES YOU SPECIFIC LEGAL RIGHTS, AND YOU MAY ALSO HAVE OTHER RIGHTS, WHICH VARY FROM STATE TO STATE.