

LCD-Kit05A
VGA Input LCD Kit of
12.1” TFT Color 800x600 – 18bits Display

©Copyright 2000 by ICP Electronics Inc. All Rights Reserved.
Manual first edition July 17, 2000.

The information in this document is subject to change without prior notice in order to improve reliability, design and function and does not represent a commitment on the part of the manufacturer.

In no event will the manufacturer be liable for direct, indirect, special, incidental, or consequential damages arising out of the use or inability to use the product or documentation, even if advised of the possibility of such damages.

This document contains proprietary information protected by copyright. All rights are reserved. No part of this manual may be reproduced by any mechanical, electronic, or other means in any form without prior written permission of the manufacturer.

Contents

1. Introduction.....	2
1.1 Specifications	3
1.2 What You Have	4
2. Installation	5
2.1 LCD-Kit05A Connection Layout.....	6
2.2 Dimension Drawing.....	7
3. LCD-Kit05A Connectors.....	8
3.1 LCD-05 Connection Board Layout.....	8
3.1.1 LCD Connector	9
3.1.2 Backlight Inverter Control	10
3.2 Backlight Connector.....	11
3.3 Touch Panel Power Connector.....	11
3.4 Brightness Setting Connector.....	11
3.5 AV-6721 Control Board.....	11
3. Appendix.....	12
Unpacking Precautions	

1

Introduction

Welcome to the LCD-Kit05A. The LCD-Kit05A is an Amorphous Silicon TFT LCD panel with VGA input and OSD (On Screen Display) control. It is made for the system manufacturers, integrators, or VARs that want to provide all the performance, quality and reliability.

The LCD-Kit05A is designed with 800 x 600 resolution and 18-bits display colors, wide view angle, High Contrast and Low Reflection to present a High Image Quality. With its compact size (12.1"), LCD-Kit05A is also the most suitable solution for OA Equipment, Display Terminals, and Industrial portable Workstation LCD monitor.

The LCD-Kit05A comes with specifically designed mounting kit for fast installation. It is also *Plug and Play*, can be directly and easily connected to any VGA port.

1.1 Kit Specifications :

- Single Supply Voltage : +12V
- Outline Dimensions : 294.0mm (W) x 240.7mm (H) x 61.0mm (D)
- Panel Size : 12.1" Diagonal
- Active Area Size: 246.0mm x 184.5mm
- Viewing Area : 247.5mm x 186.0mm
- Display Colors : 256k Colors by the combinations of 18 bits data
- Number of Pixels : 800 (W) x 600 (H)
- Brightness : 250 cd/m²
- Pixel Pitch : 0.3075mm (H) x 0.3075mm (V)
- Viewing Angle : Vertical = 90°, Horizontal = 110°
- Contrast Ratio : 250 : 1
- Surface Treatment : Anti-glare and Hard Coat
- Backlight: Twin Cold-Cathode Fluorescent Lamps for sidelighting
- Operating Temperature : 0~50°C
- LCD MTBF : 50,000 hours
- Backlight MTBF : 25,000 hours (avr.)
- VGA Input
- OSD built
- RS232 I/F Touch Panel (option)

1.2 What You Have

In addition to this *User's Manual*, the LCD-Kit05A package includes the following items:

- AC-6721 User's Manual
- LCD-Kit05A User's Manual
- Power adapter
- AC power cord
- VGA cable (1.8M)

If any of these items is missing or damaged, contact the dealer from whom you purchased the product. Save the shipping materials and carton in case you want to ship or store the product in the future.

2

Installation

This chapter describes how to install the LCD-Kit05A and include all connections description such as jumpers, connectors and switches setting. The layout of LCD-Kit05A connectors are shown on the next chapter. The reference manual of AV-6721 control board are separated on attached booklet. Also the Unpacking Precautions are shown on appendix that you should be careful with are described on the following page.

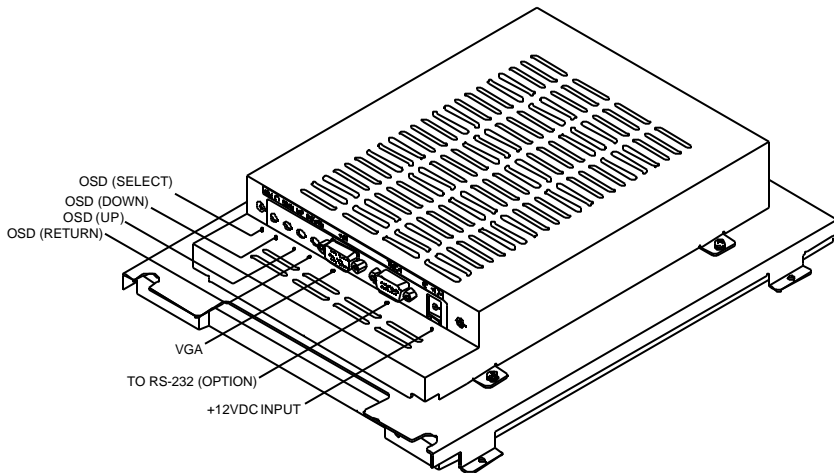

2.1 LCD-Kit05A Connection Layout

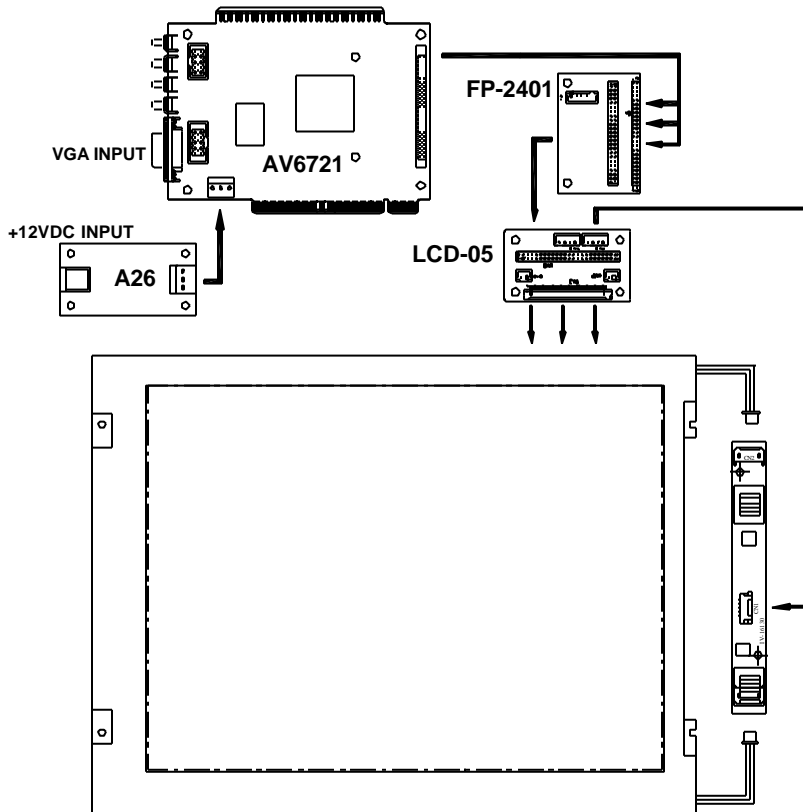

2.2 LCD-Kit05A Dimension Drawing

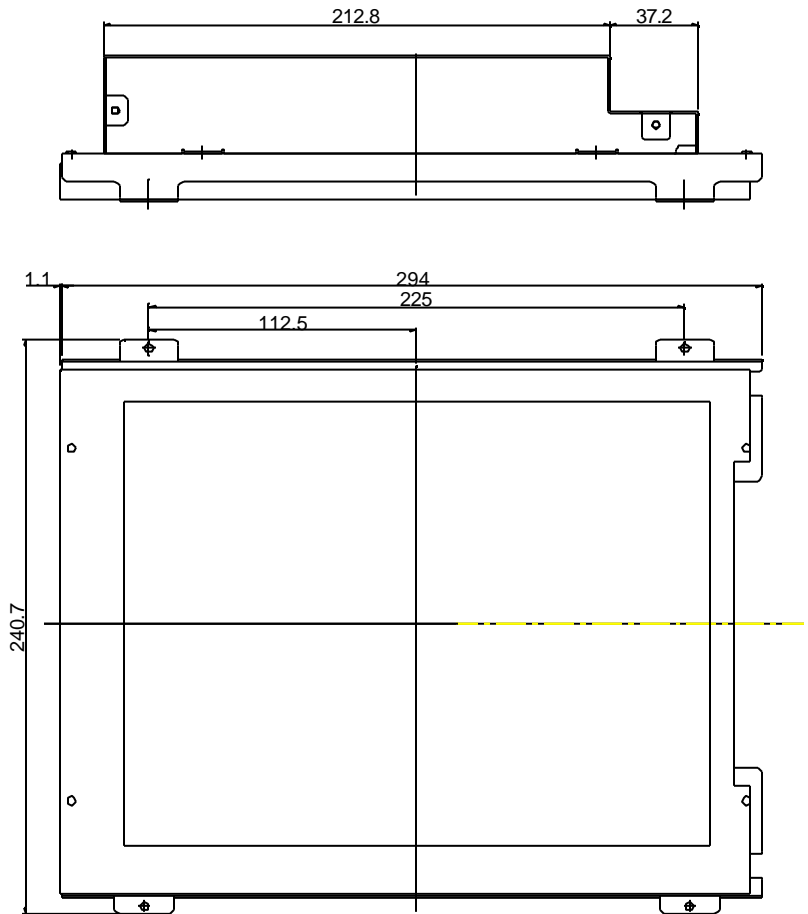

3

LCD-Kit05A Connectors

3.1 LCD-05 Connection Board Layout

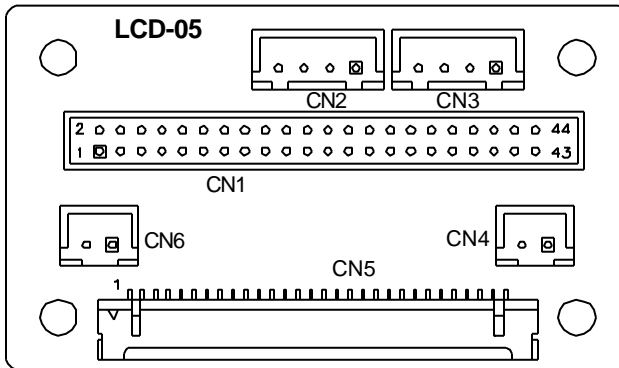

3.1.1 LCD Connector

- **CN1: 22x2 Header/2.0mm LCD Connector**
(connect to LCD Control Card)

PIN NO	FUNCTION	PIN NO	FUNCTION
1	+12V	2	+12V
3	GND	4	GND
5	+5V	6	+5V
7	FPVEE	8	GND
9	P0	10	P1
11	P2	12	P3
13	P4	14	P5
15	P6	16	P7
17	P8	18	P9
19	P10	20	P11
21	P12	22	P13
23	P14	24	P15
25	P16	26	P17
27	P18	28	P19
29	P20	30	P21
31	P22	32	P23
33	GND	34	GND
35	SHFCLK	36	FLM
37	M	38	LP
39	GND	40	ENBKL
41	GND	42	NC
43	+5V	44	+5V

- **CN5: LCD OUTPUT (DF14-30P-1.25H) Connector**
(connect to Panel Display)

PIN NO.	DESCRIPTION	PIN NO.	DESCRIPTION
1	GND	2	SHFCLK
3	NC	4	NC
5	GND	6	P18
7	P19	8	P20
9	P21	10	P22
11	P23	12	GND
13	P10	14	P11
15	P12	16	P13
17	P14	18	P15
19	GND	20	P2
21	P3	22	P4
23	P5	24	P6
25	P7	26	M
27	GND	28	+5V
29	+5V	30	GND

3.1.2 Backlight Inverter Control

- **JP1: Backlight Inverter ON/OFF control - jumper**

PIN NO.	FUNCTION
1-2	USE FPVEE
2-3	USE ENBKL

3.2 Backlight Connector

• **CN2: Backlight Inverter Connector**

PIN NO.	DESCRIPTION
1	Vin (+12V)
2	ON/OFF
3	GND
4	VR

• **CN4: JST-2Pin/2.5mm Backlight Inverter ON/OFF Switch**

PIN NO.	DESCRIPTION
1	+12V
2	Vin

1-2 ON : Backlight Inverter ON

1-2 OFF : Backlight Inverter OFF

3.3 Touch Panel Power Connector

• **CN3: Touch Panel Power Connector**

PIN NO.	DESCRIPTION
1	+12V
2	GND
3	GND
4	+5V

3.4 Brightness Setting Connector

• **CN6: Brightness VR Connector**

PIN NO.	DESCRIPTION
1	Series Resistor to VCC
2	VR
3	GND

Note: Pin1 is reserved for potentiometer

3.5 AV-6721 Control Board

The AV-6721 Control Board is worked for VGA control; all detail as feature and connection information please refer to “AV-6721 User Manual”

Appendix

Unpacking Precautions

- ✓ Some components on LCD-Kit05A are very sensitive to static electric charges and can be damaged by a sudden rush of power. Ground yourself to remove any static charge before touching your LCD-Kit05A. You can do it by using a grounded wrist strap at all times or by frequently touching any conducting materials that is connected to the ground.
- ✓ Do not touch the inner side of LCD panel and the connector/cable of fluorescent lamp/backlight when the power is on. The inverter supplies HIGH VOLTAGE to these parts (~ 630Vrms).
- ✓ Disconnect power supply before handling and doing connection on LCD-Kit05A. Do not plug any connector or jumper while the power is on. It will cause fatal damage to your LCD panel.
- ✓ Make sure that every connector is connected in correct direction. Any incorrect connection may cause smoke or burn of electrical parts or fatal damage of your LCD panel.
- ✓ Be careful with the liquid crystal material. Do not swallow, inhale or have skin contact with this material in case that the LCD panel is broken and the liquid flow out. If you inhale the liquid material, rinse your mouth immediately with water then go to see a doctor. If you

have skin contact with the liquid, wash it immediately with alcohol. Be careful, too, with the chips of glass if the panel is broken.

- ✓ For outdoor usage, an ultra-violet ray protect-lens is recommended to apply onto LCD display. It will prevent your LCD from strong sunlight, scratches, dust and water invasion etc. which can cause damage to the LCD display.