

LCD-Kit01
640x480 – 18bits
P64CV1 LCD Display

©Copyright 1999 by ICP Electronics Inc. All Rights Reserved.
Manual first edition May01, 1999.

The information in this document is subject to change without prior notice in order to improve reliability, design and function and does not represent a commitment on the part of the manufacturer.

In no event will the manufacturer be liable for direct, indirect, special, incidental, or consequential damages arising out of the use or inability to use the product or documentation, even if advised of the possibility of such damages.

This document contains proprietary information protected by copyright. All rights are reserved. No part of this manual may be reproduced by any mechanical, electronic, or other means in any form without prior written permission of the manufacturer.

Contents

1. Introduction.....	2
1.1 Specifications	3
1.2 What You Have	4
2. Installation	5
2.1 LCD-01 Connection Board Layout.....	5
2.2 LCD-Kit01 Connection Layout.....	6
2.3 Unpacking Precautions.....	7
2.4 Horizontal and Vertical Image Shift	8
2.5 Backlight Inverter Control	9
3. LCD-Kit01 Connectors.....	10
3.1 LCD Connector	10
3.2 Backlight Connector.....	14
3.3 Keyboard Connector	14
4. Voltage and BIOS Setting	15
4.1 BIOS Setting for SBCs with C&T 65555 Chipset.....	16
4.2 BIOS Setting for SBCs with HM86508 Chipset.....	17
Appendix A. P64CV1 Display - Switch Setting..	18

1

Introduction

Welcome to the LCD-Kit01 – P64CV1. The LCD-Kit01 is high brightness Amorphous Silicon TFT LCD panel with 640 x 480 resolution and 18-bits display colors. It is compatible with VGA-480, VGA-400, VGA-350 and free format – four kinds of VGA timing. It is made for the system manufacturers, integrators, or VARs that want to provide all the performance, reliability, and quality at a reasonable price.

The LCD-Kit01 is designed with Color Filter, Wide View Angle, High Contrast and Aperture Ratio to present a High Image Quality. With its thin and light weight *plus* small and compact size (6.4”), LCD-Kit01 is also the most suitable solution for industrial portable workstation.

The LCD-Kit01 comes with specifically designed mounting kit for fast installation. It is also *Plug and Play*, can be directly and easily connected to JUKI, NOVA, POS,... series main boards and also PLC-655, PLC-508 LCD control card without any additional parts needed.

1.1 Specifications :

Supply Voltage : +5V

Panel Size : 6.4" (17cm) Diagonal

Display Active Area Size: 129.60mm (H) x 97.44mm (V)

Total Display Size : 140.12mm (H) x 110.00mm (V)

Display Colors : 18-bits = 262.144 Colors

Number of Pixels : 640 (H) x 480 (V)

Brightness : 300 cd/m²

Pixel Format : 1 pixel = R + G + B dots

Pixel Arrangement : R, G, B Vertical Strip

Pixel Pitch : 203 μ m (H) x 203 μ m (V)

Dot Pitch : 67.5 μ m (H) x 203 μ m (V)

Image Reversion : Up/Down and Left/Right

Viewing Direction : 6 o' clock

Viewing Angle : +/- 50° (H), -10° ~ +30° (V)

Contrast Ratio : > 100 : 1

Outline Dimensions : 168.9mm (W) x 120.0mm (H) x 13.0mm (D)

Surface Treatment : Hard Coating (or Anti-reflection)

Operating Temperature : 0~55°C

LCD MTBF : 50,000 hours

Backlight MTBF : 10,000 hours (min)

1.2 What You Have

In addition to this *User's Manual*, the LCD-Kit01 package includes the following items:

- one P64CV1 6.4" LCD Panel with its mounting kit
- one 70cm 44-pin LCD connection cable
- one BIOS Utility Diskette

If any of these items is missing or damaged, contact the dealer from whom you purchased the product. Save the shipping materials and carton in case you want to ship or store the product in the future.

2

Installation

This chapter describes how to install the LCD-Kit01. The layout of LCD-01 Connection Board is shown on the next page and the Unpacking Precautions that you should be careful with are described on the following page. Also included is the jumpers, connectors and switches setting for this LCD-Kit01.

2.1 LCD-01 Connection Board Layout

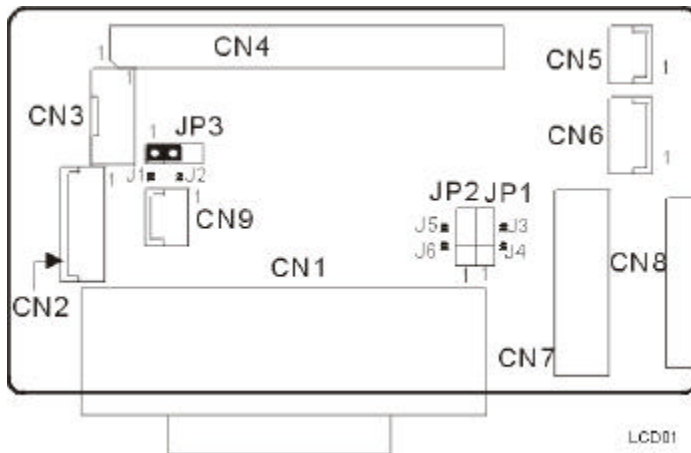

2.2 LCD-Kit01 Connection Layout

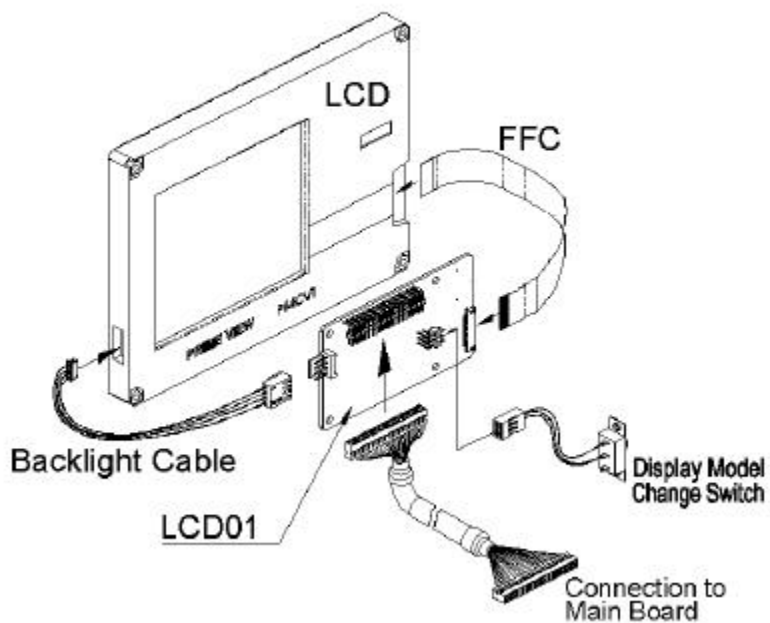

2.3 Unpacking Precautions

- ✓ Some components on LCD-Kit01 are very sensitive to static electric charges and can be damaged by a sudden rush of power. Ground yourself to remove any static charge before touching your LCD-Kit01 . You can do it by using a grounded wrist strap at all times or by frequently touching any conducting materials that is connected to the ground.
- ✓ Do not touch the inner side of LCD module and the connector/cable of fluorescent lamp/backlight when the power is on. The inverter supplies HIGH VOLTAGE to these parts (~ 300Vrms).
- ✓ Disconnect power supply before handling and doing connection on LCD-Kit01. Do not plug any connector or jumper while the power is on. It will cause fatal damage to your LCD panel.
- ✓ Make sure that every connector is connected in correct direction. Any incorrect connection may cause smoke or burn of electrical parts or fatal damage of your LCD panel.
- ✓ Be careful with the liquid crystal material. Do not swallow, inhale or have skin contact with this material in case that the LCD panel is broken and the liquid flow out. If you inhale the liquid material, rinse your mouth immediately with water then go to see a doctor. If you have skin contact with the liquid, wash it immediately with alcohol. Be careful, too, with the chips of glass if the panel is broken.

2.4 Horizontal and Vertical Image Shift

- **JP1 : Horizontal Image Shift-direction Jumper**

This setting also can be done by shorting J3 or J4

Disaster note: Do not short both J3 and J4

- **JP2 : Vertical Image Shift-direction Jumper**

This setting also can be done by shorting J5 or J6

Disaster note: Do not short both J5 and J6



JP2 JP1



*default
setting*



JP2 JP1



*or J3 pad
short*

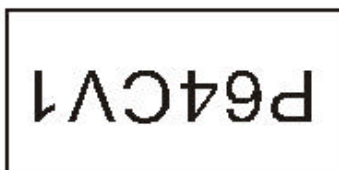

JP2 JP1



*or J3, J5 pads
short*

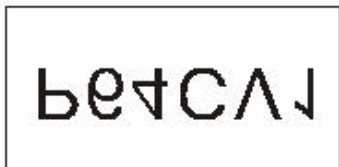

JP2 JP1



or J5 pad short

2.5 Backlight Inverter Control

- **JP3: Backlight Inverter ON/OFF control**

PIN NO.	FUNCTION
1-2	USE FPVVEE
2-3	USE ENBKL

- **J1, J2: Backlight Inverter ON/OFF control,**

Use these jumpers only if JP3 is not in use (short pad)

J1	J2	FUNCTION
OFF	ON	ENBKL
ON	OFF	FPVVEE

3

LCD-Kit01 Connectors

3.1 LCD Connector

CN1 or CN4 can be used as LCD Connector to connect your LCD-Kit01 to the LCD Control Card of your SBC. Choose only one of them.

- **CN4: 22x2 Header/2.0mm LCD Connector**
(connect to LCD Control Card)

PIN NO	FUNCTION	PIN NO	FUNCTION
1	+12V	2	+12V
3	GND	4	GND
5	+5V	6	+5V
7	FPVEE	8	GND
9	P0	10	P1
11	P2	12	P3
13	P4	14	P5
15	P6	16	P7
17	P8	18	P9
19	P10	20	P11
21	P12	22	P13
23	P14	24	P15
25	P16	26	P17
27	P18	28	P19
29	P20	30	P21
31	P22	32	P23
33	GND	34	GND

35	SHFCLK	36	FLM
37	M	38	LP
39	GND	40	ENBKL
41	GND	42	NC
43	+5V	44	NC

• **CN1: DSUB-44 Pin LCD Connector**

(connect to LCD Control Card; optional)

Pin	Function	Pin	Function	Pin	Function
1	+12V	16	P7	31	P22
2	+12V	17	P8	32	P23
3	GND	18	P9	33	GND
4	GND	19	P10	34	GND
5	+5V	20	P11	35	SHFCLK
6	+5V	21	P12	36	FLM
7	FPVEE	22	P13	37	M
8	GND	23	P14	38	LP
9	P0	24	P15	39	GND
10	P1	25	P16	40	ENBKL
11	P2	26	P17	41	KB-DAT
12	P3	27	P18	42	KB-CLK
13	P4	28	P19	43	C-VR1
14	P5	29	P20	44	C-VR2
15	P6	30	P21		

• **CN8: LCD OUTPUT Connector**
(connect to Panel Display)

PIN NO.	FUNCTION	PIN NO.	FUNCTION
1	SHFCLK	16	P14
2	LP	17	P15
3	FLM	18	GND
4	GND	19	P2
5	P18	20	P3
6	P19	21	P4
7	P20	22	P5
8	P21	23	P6
9	P22	24	P7
10	P23	25	GND
11	GND	26	M
12	P10	27	+5V
13	P11	28	+5V
14	P12	29	R/L *
15	P13	30	U/D *

Note:1. * the same function as CN7

2. Choose only one of CN8 or CN7 to be used.

• **CN7: LCD OUTPUT DF9-31S-1V Connectors**
 (connect to Panel Display; optional)

PIN NO.	FUNCTION	PIN NO.	FUNCTION
1	GND	2	SHFCLK
3	LP	4	FLM
5	GND	6	P18
7	P19	8	P20
9	P21	10	P22
11	P23	12	GND
13	P10	14	P11
15	P12	16	P13
17	P14	18	P15
19	GND	20	P2
21	P3	22	P4
23	P5	24	P6
25	P7	26	GND
27	M	28	+5V
29	+5V	30	R/L *
31	U/D **		

Note: * R/L is the Right/Left shift signal for LCD P64CV1

** U/D is the Up/Down shift signal for LCD P64CV1

3.2 Backlight Connector

- **CN3: Backlight Inverter Connector**

PIN NO.	DESCRIPTION
1	+12V
2	Vadj
3	GND
4	ON/OFF

- **CN5: JST-2Pin/2.5mm Backlight Inverter ON/OFF Switch**

PIN NO.	DESCRIPTION
CLOSE	Inverter ON
OPEN	Inverter OFF

- **CN6: JST-3Pin/2.5mm Backlight VR Connector**
(Resistor Potentiometer)

PIN NO.	DESCRIPTION
1	Series 1K Ohm To +5V
2	Vadj
3	GND

Note: This Connector is plugged with 3-Wired VR

3.3 Keyboard Connector

• **CN2: Keyboard Connector (JST-5Pin/2.5mm; optional)**

PIN NO.	DESCRIPTION
1	KB-CLK
2	KB-DAT
3	NC
4	GND
5	+5V

Note: This is an optional connector. It can be used only in connection with **PM-1035 DC to DC Module** under the situation where the distance between your SBC and LCD display is 70cm ~ 2m. Visit www.icpacquire.com.tw for more information on PM-1035.



Voltage and BIOS Setting

After all jumpers and connectors have been set and connected correctly, the next step is to set the Voltage and BIOS of the LCD-Kit01. These settings are done on your SBC.

Voltage Setting

The Supply Voltage for LCD-Kit01 is +5V. You must set the *LCD Voltage Setting* Jumper on your SBC to +5V. Please, refer to SBC User Manual of your SBC or refer to the following tables.

BIOS Setting

For SBCs with C&T 65555 LCD/CRT Interface Chipset, the setting can be done simply in CMOS Setup. For SBCs with HM86508 LCD/CRT Interface Chipset, the BIOS setting must be done by upgrading the VGA BIOS using the BIOS file in the attached disk.

Please, refer to the following tables for more detail information.

Note: To do the above settings, you must have one VGA monitor connected to your SBC because your LCD-Kit01 may not work correctly or even does not show anything before the Voltage and BIOS settings are correct.

4.1 BIOS Setting for SBCs with C&T 65555 Chipset

LCD-Kit01

	BIOS Setup	LCD Volt. Setting
JUKI-710	Standard CMOS Setup: LCD&CRT: Auto or Both Panel & P.M.U. Setup: Panel Type: 6 :640x480 18Bit TFT Color	JP9: 2-3 > ON 5-6 > ON
JUKI-740E	Peripheral Setup: LCD&CRT Selection : Auto or Both LCD Type : #6 640x480 18bit	JP39: 2-3 > ON
JUKI-745E	Peripheral Setup: LCD CRT Selection: Auto or Both LCD Type : #6 640x480 18bit	JP39: 2-3 > ON
NOVA-600	Peripheral Setup: LCD CRT Selection: Auto or Both LCD Type : #6 640x480 18bit	JP10: 2-3 > ON
POS-566	Peripheral Setup: LCD CRT Selection: Auto or Both LCD Type : #6 640x480 18bit	JP23: 2-3 > ON
LCD-Kit01 640 x 480 / 18 bits		

4.2 BIOS Setting for SBCs with HM86508 Chipset

LCD-Kit01

	BIOS Setup	LCD Volt. Setting
JUKI-730 (ALi6117)	use flash634 j730lcd1.rom to upgrade bios	No volt. Setting (5V only)
JUKI-732E (ALi6117)	use flash634 j732lcd1.rom to upgrade bios	No volt. Setting (5V only)
JUKI-750E (ACC Maple)	use flash631 j750lcd1.rom to upgrade bios	No volt. Setting (5V only)
JUKI-752 (ACC Maple)	use flash631 j752lcd1.rom to upgrade bios	No volt. Setting (5V only)
PM-1021 (ALi6117)	use flash634 1021lcd1.rom to upgrade bios	No volt. Setting (5V only)
NOVA-300 (ALi6117)	use flash634 n300lcd1.rom to upgrade bios	No volt. Setting (5V only)
WALPO-4301 (ACC Maple)	use flash634 w4301lcd1.rom to upgrade bios	No volt. Setting (5V only)

Note : to upgrade the BIOS, under DOS prompt insert the attached disk then type the bold letter command of the middle column then follow the instruction on your monitor.

Example: for NOVA-300 SBC, under DOS prompt type:

A:\ **flash634 n300lcd1.rom** or

C:\ **flash634 n300lcd1.rom** if you have copied the files *flash634.com* and *n300lcd1.rom* to your hard-disk.

Appendix A. P64CV1 Display – Switch Setting

There are two switches on the back of LCD01 Display. These switches have been set to the factory-setting. Your LCD01 comes in ready-to-use condition, don't change this setting unnecessary.

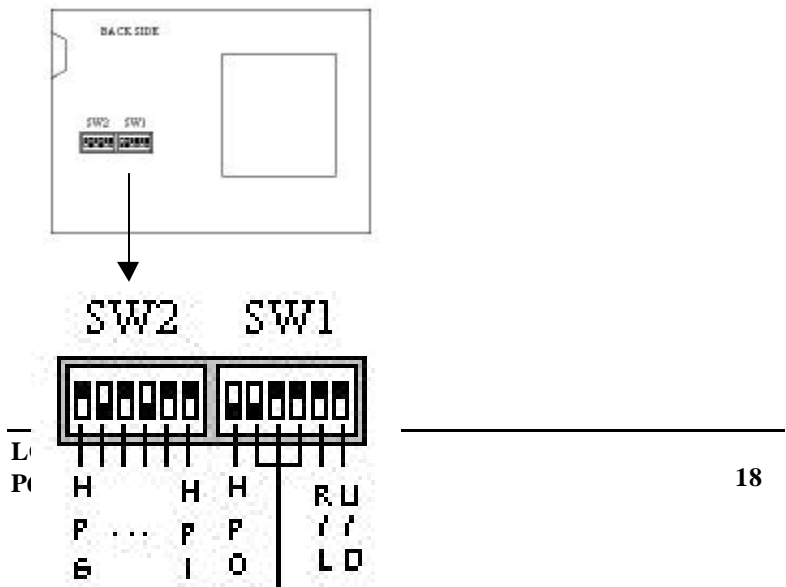

- Notes:
1. HP6~HP0 is for picture level setting
 2. U/D is for picture horizontal rotation
 3. R/L is for picture vertical rotation
 4. Don't change the 'system internal setting'